

THG[®]
P A R I S

*Boutons
& Poignées*

THG[®]
PARIS

J&D[®]
CREATIONS
Jean-Claude DIELEPINE
PARIS

LALIQUE

BERNARDAUD

AP
ALBERTO PINTO

J

JAMIE DRAKE

PYR

PIERRE-YVES ROCHON



LALIQUE
Pages 8 à 23

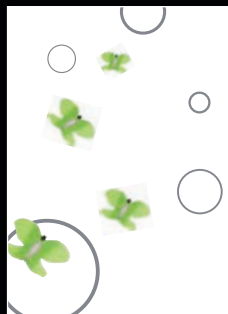

BERNARDAUD
Pages 24 à 29



Alberto PINTO
Pages 30 à 33



Pierre-Yves ROCHON
Pages 34 à 39



Jamie DRAKE
Pages 40 à 45



CONTEMPORAINE
Pages 46 à 55



CRISTAL
Pages 56 à 65



CLASSIQUE
Pages 66 à 71



BAROQUE
Pages 72 à 77



PIERRE
Pages 78 à 91

NOS RÉFÉRENCES

<i>Project references</i>	
Projektbezugsnahmen	4-7

LES COLLECTIONS

COLLECTIONS / KOLLEKTIONEN

LALIQUE

Mossi	12-13
Masque de femme	14-17
Métropolis	18-19
Cactus	20
Samoa	20
Thaïs	20
Profil Cristal	21
Océania	23
Panthère	23

BERNARDAUD

Capucine	28
Passion	28
Ithaque	29
Marquise	29

ALBERTO PINTO

Le 11 by Alberto Pinto	33
------------------------	----

PIERRE-YVES ROCHON

Faubourg	39
Frivole	39
Froufrou	39

JAMIE DRAKE

Profil	44
--------	----

CONTEMPORAINE

Cubica	48
Pullman	49
Diplomate lisse	50
Diplomate annelée	51
Alto	52
Charleston	52
Jaipur métal	53
Shao	54
Tango	54

Cotton	55
Eden	55
Mercure	55

CRISTAL

Mandarine Cristal	58-61
Mandarine Cristallia Diamant	62
Diamant	63
Luna	63
Art Déco Cristal	64-65

CLASSIQUE

Tradition	68
Art Déco	69
Diplomate torsadée	70
1900	71
Broadway	71

BAROQUE

Médicis	74
Venezia	75
Mandarine	76
Versailles	77

PIERRE

Amboise	80-81
Vogue	82-83
Cheverny	84
Sully	85
Trocadéro	86
Jaipur	87
Médicis Pierre	88-89
Venezia Pierre	90-91

ACCESSOIRES

POIGNÉES DE PORTE

<i>Hardware</i>	
Türlinke Accessoires	94-97

THG SERVICES

<i>THG Services</i>	98-104
---------------------	--------

SÉRIES

Lines
Serien

1900	71
Accessoires & Poignées de porte /Hardware	94-97
Alto	52
Amboise	80-81
Art Déco	69
Art Déco Cristal	64-65
Broadway	71
Cactus	20
Capucine	28
Charleston	52
Cheverny	84
Cotton	55
Cubica	48
Diamant	63
Diplomate annelée	51
Diplomate lisse	50
Diplomate torsadée	70
Eden	55
Faubourg	39
Frivole	39
Froufrou	39
Ithaque	29
Jaipur	87
Jaipur Métal	53

Le 11 by Alberto Pinto	33
Luna	63
Mandarine	76
Mandarine Cristal	58-61
Mandarine Cristallia Diamant	62
Marquise	29
Masque de femme	14-17
Médecis	74
Médecis Pierre	88-89
Mercuré	55
Métropolis	18-19
Mossi	12-13
Océania	23
Panthère	23
Passion	28
Profil	44
Profil Cristal	21
Pullman	49
Samoa	20
Shao	54
Sully	85
Tango	54
Thais	20
Tradition	68
Trocadéro	86
Venezia	75
Venezia Pierre	90-91
Versailles	77
Vogue	82-83



1. Intercontinental (Paris)
2. Le Ritz (Paris)
3. Scribe (Paris)
4. Fouquet's (Paris)
5. Monte Carlo Bay (Monaco)
6. Shangri La (Paris)

Références

Project references

Projektbezugnahmen



Partout où esthétique et raffinement se conjuguent au quotidien, THG apporte aux hommes les clefs d'un paradis retrouvé.

Everywhere where beauty and refinement combine daily, THG provide people with the keys of a rediscovered paradise.

Überall dort, wo sich gleichermaßen Funktion, Ästhetik und Erlesenheit vereinen, inszenieren THG tagtäglich das Paradies auf Erden.

1. Amnesia - 2. Squall - 3. Delphine



1 2
3 4



5 6

1. Samsung Tower (Seoul)
2. Pan Gu (Beijing)
3. Hôtel Bellagio (Las Vegas)
4. Sanya (Phoenix Island)
5. Hotel Wynn (Las Vegas)
6. Peninsula (Shanghai)

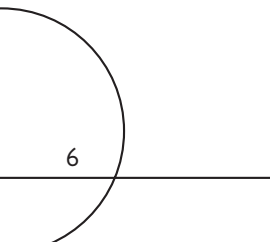

Références

Project references

Projektbezugnahmen

Des références prestigieuses aux quatre coins du monde...

Prestigious references everywhere in the world...

Glanzvolle Verweise überall in der Welt...

1

2



1. Hôtel Burj Al Arab (Dubai) - 2. Emirates Palace (Abu Dhabi)





Collection LALIQUE

design 
CREATIONS
Jewelry - Watches - Perfumes
PARIS



Un savoir-faire exceptionnel
au service de la création et de l'émotion...

*Exceptional know-how
serving creativity and emotion...*

Außergewöhnliche Fachkenntnis im Dienste
von Kreativität und Emotionen ...

Depuis 2002, JCD Créations, célèbre robinetier de style français
et LALIQUE, manufacture emblématique d'objets en cristal,
ont uni leurs savoir-faire respectifs afin de proposer une gamme luxueuse
et raffinée de robinetteries, d'accessoires, de boutons de meuble et de poignées de porte.

*Since 2002, JCD Creations, renowned French fittings manufacturer and LALIQUE
the symbolic factory for crystal items, have combined their expertise to offer
a luxurious and refined range of fittings, accessories, cabinet knobs and door handles.*

Bereits seit 2002 entwickeln der renommierte Armaturenhersteller
aus Frankreich JCD Creations und LALIQUE-das Sinnbild für Kristallerzeugnisse-
mit kombinierter Fachkenntnis ihre Kollektionen luxuriös veredelter Armaturen und
Accessoires sowie Schrank- und Türgriffen.



LALIQUE

SCULPTEUR DE LUMIÈRE...

Depuis 1921, la manufacture LALIQUE installée en Alsace, région de tradition verrière, perpétue un véritable savoir-faire artisanal. La main de l'homme, artiste-artisan de la matière, marque les objets de son empreinte et leur confère cette force, cette présence très « immatérielle ». Le style LALIQUE naît sous le geste de l'artiste esquissant un dessin en osmose totale avec la matière, un style reconnaissable au modelage manuel des pièces et des décors, comme une sculpture, à la caractéristique de cristal clair et satiné. Une culture de la douceur, de la féminité, de la nature nourrie d'une forte inspiration Art Nouveau et Art Déco. Quand ce qui est contenu dans la matière naît à la lumière, LALIQUE dans un geste artistique, métamorphose la matière brute en des objets uniques qui méritent le statut d'œuvres d'art.

LIGHT SCULPTOR...

For more than 100 years, Lalique's manufacture located in Alsace, area renowned for its glassmaking, has perpetuated a traditional know-how. The human hand, that of both artist and craftsman, marks every object of its print and its strength, which convey this «immaterial» presence: our know-how. The LALIQUE style comes from an artistic gesture, outlining a drawing in total osmosis with crystal, a style that one easily recognises through the manual modelling of the shapes and patterns, as if sculptured, the richness of the figurative details, the different types of finishing which creates this characteristic contrast of clear and matt crystal. An identity built by softness, femininity, nature with strong Art Nouveau and Art Deco inspirations. When what is contained in the matter is revealed through the light... LALIQUE, the only crystal Brand which, through an artistic gesture metamorphoses raw material into unique artworks.

SKULPTUR DES LICHTS...

Seit über hundert Jahren bewahren wir in der Manufaktur von LALIQUE im Elsass, eine für seine Glasarbeiten berühmte Region, das überlieferte Know-how. Die Hand des Künstlers und die des Handwerkers, ihre Besonderheiten und ihre Stärken, sind in jedem Objekt zu erkennen und vermitteln eine «immaterielle» Präsenz: unser Know-how. Der LALIQUE-Stil entstammt einem künstlerischen Ausdruck; er umreißt eine Abbildung in vollständiger Osmose mit dem Kristall. Ein Stil, der sich durch die manuelle Modellage der skulpturähnlichen Formen und Muster, den Reichtum an bildlichen Details und die unterschiedliche Oberflächenbehandlung zu erkennen gibt, mit der der charakteristische Kontrast von glänzendem und matten Kristall erreicht wird. Diese Individualität wird erzeugt durch Sanftheit, Weiblichkeit und Naturelemente mit starken Jugendstil- und Art-déco-Einflüssen. Wenn Licht das Innere des Körpers zum Vorschein bringt ... LALIQUE, die einzige Marke für Kristallerzeugnisse, die den Rohstoff durch künstlerischen Ausdruck und die Verbindung in ein Kunstwerk verwandelt, das seinesgleichen sucht.



Mossi

Bouton petit modèle
Small size cabinet knob
Kleiner Knopf

Cristal clair / Clear crystal / Klarer Kristall
Ref. A11.26BT/A2NC

Cristal soleil / Sun crystal / Kristall Soleil
Ref. A11.26BT/A2PS

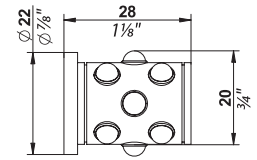

Mossi

Bouton moyen modèle
Medium size cabinet knob
Mittelgrosser Knopf

Cristal clair / Clear crystal / Klarer Kristall
Ref. A11.26BP/A2NC

Cristal soleil / Sun crystal / Kristall Soleil
Ref. A11.26BP/A2PS

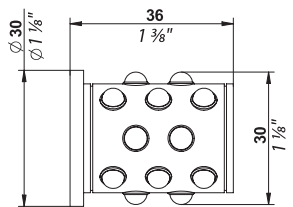

Mossi

Cristal clair / Clear crystal / Klarer Kristall

- ❶ Bouton grand modèle / Door knob / Grosser Knopf
L'unité / Per piece / ProStück - Ref. A11.639V/A2N
La paire / Per pair / Das Paar - Ref. A11.638V/A2N

- ❷ Poignée de porte - Carré de 7 & 8 mm
Door handle - 7 & 8mm spindle
Türknohf - Stift 7 & 8 mm
L'unité / Per piece / ProStück - Ref. A11.639/A2N
La paire / Per pair / Das Paar - Ref. A11.638/A2N

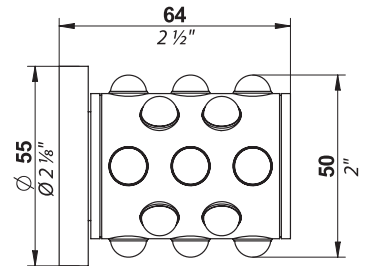

- ❶ Bouton grand modèle
Door knob
Grosser Knopf



Mossi

Cristal soleil / Sun crystal / Kristall Soleil

- ❶ Bouton grand modèle / Door knob / Grosser Knopf
L'unité / Per piece / ProStück - Ref. A11.639V/A2P
La paire / Per pair / Das Paar - Ref. A11.638V/A2P

- ❷ Poignée de porte - Carré de 7 & 8 mm
Door handle - 7 & 8mm spindle
Türknohf - Stift 7 & 8 mm
L'unité / Per piece / ProStück - Ref. A11.639/A2P
La paire / Per pair / Das Paar - Ref. A11.638/A2P

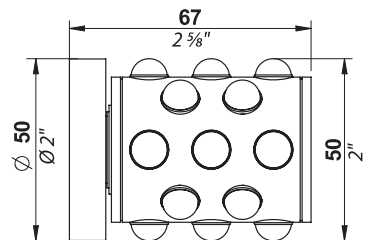

- ❷ Poignée de porte
Door handle
Türknohf



LALIQUE
MASQUE DE FEMME

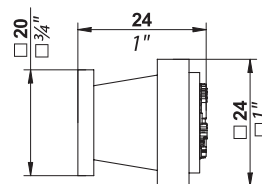

Masque de femme

Métal lisse / Smooth metal / Metall glatt

Bouton petit modèle
Small size cabinet knob
Kleiner Knopf

Ref. A I I .26BT/A2U

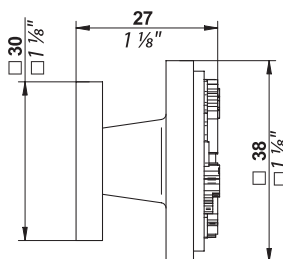

Masque de femme

Métal lisse / Smooth metal / Metall glatt

Bouton moyen modèle
Medium size cabinet knob
Mittelgrosser Knopf

Ref. A I I .26BP/A2U



LALIQUE
MASQUE DE FEMME



Masque de femme
Métal lisse / Smooth metal / Metall glatt

- 1 Bouton grand modèle / Door knob / Grosser Knopf
L'unité / Per piece / ProStück - Ref. A11.639V/A2U
La paire / Per pair / Das Paar - Ref. A11.638V/A2U

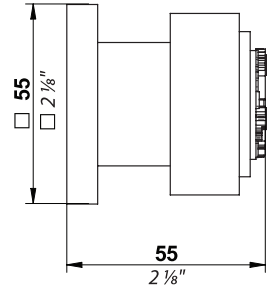

Masque de femme
Métal lisse / Smooth metal / Metall glatt

- 2 Poignée de porte - Carré de 7 & 8 mm
Door handle - 7 & 8mm spindle
Türknoopf - Stift 7 & 8 mm
L'unité / Per piece / ProStück - Ref. A11.639/A2U
La paire / Per pair / Das Paar - Ref. A11.638/A2U



- 1 Bouton grand modèle
Door knob
Grosser Knopf



Masque de femme
Métal gravé / Engraved metal / Metall graviert

- 1 Bouton grand modèle / Door knob / Grosser Knopf
L'unité / Per piece / ProStück - Ref. A11.639V/A2T
La paire / Per pair / Das Paar - Ref. A11.638V/A2T

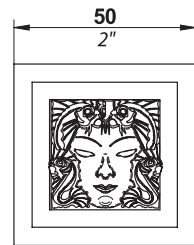
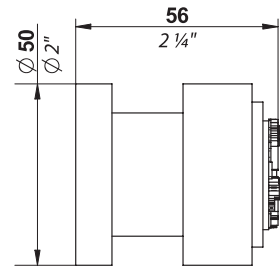

- 2 Poignée de porte
Door handle
Türknoopf



Masque de femme
Métal gravé / Engraved metal / Metall graviert

- 2 Poignée de porte - Carré de 7 & 8 mm
Door handle - 7 & 8mm spindle
Türknoopf - Stift 7 & 8 mm
L'unité / Per piece / ProStück - Ref. A11.639/A2T
La paire / Per pair / Das Paar - Ref. A11.638/A2T



Masque de femme solaire

- 1 Bouton grand modèle / Door knob / Grosser Knopf
L'unité / Per piece / ProStück - Ref. A11.639V/A2S
La paire / Per pair / Das Paar - Ref. A11.638V/A2S

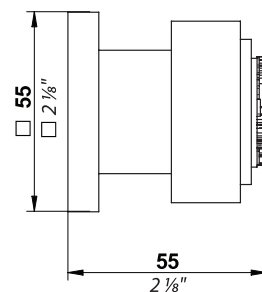

Masque de femme solaire

- 2 Poignée de porte - Carré de 7 & 8 mm
Door handle - 7 & 8mm spindle
Türknoopf - Stift 7 & 8 mm
L'unité / Per piece / ProStück - Ref. A11.639/A2S
La paire / Per pair / Das Paar - Ref. A11.638/A2S

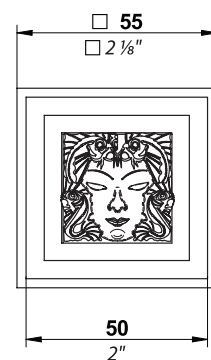

- 1 Bouton grand modèle
Door knob
Grosser Knopf



Masque de femme lunaire

- 1 Bouton grand modèle / Door knob / Grosser Knopf
L'unité / Per piece / ProStück - Ref. A11.639V/A2R
La paire / Per pair / Das Paar - Ref. A11.638V/A2R

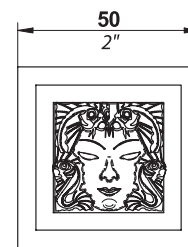
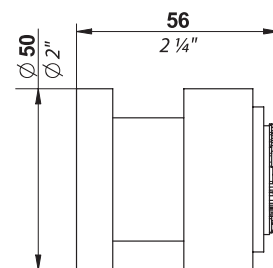

- 2 Poignée de porte
Door handle
Türknoopf



Masque de femme lunaire

- 2 Poignée de porte - Carré de 7 & 8 mm
Door handle - 7 & 8mm spindle
Türknoopf - Stift 7 & 8 mm
L'unité / Per piece / ProStück - Ref. A11.639/A2R
La paire / Per pair / Das Paar - Ref. A11.638/A2R

LALIQUE
MÉTROPOLIS



Métropolis

Bouton moyen modèle
Medium size cabinet knob
Mittelgrosser Knopf

Cristal clair / Clear crystal / Klarer Kristall
Ref. A11.26BP/A2A

Cristal noir / Black crystal / Schwarzer Kristall
Ref. A11.26BP/A2L

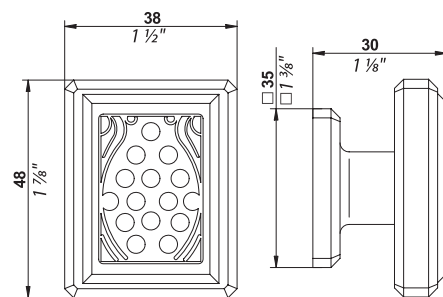



Métropolis

Cristal clair / Clear crystal / Klarer Kristall

- 1 Bouton grand modèle / Door knob / Grosser Knopf
L'unité / Per piece / ProStück - Ref. A11.639V/A2A
La paire / Per pair / Das Paar - Ref. A11.638V/A2A



Métropolis

Cristal clair / Clear crystal / Klarer Kristall

- 2 Poignée de porte - Carré de 7 & 8 mm
Door handle - 7 & 8mm spindle / Türknopf - Stift 7 & 8 mm
L'unité / Per piece / ProStück - Ref. A11.639/A2A
La paire / Per pair / Das Paar - Ref. A11.638/A2A

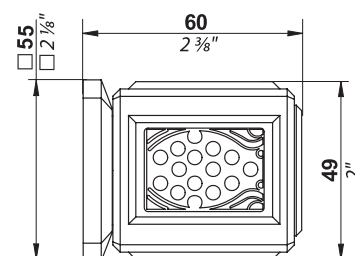

- 1 Bouton grand modèle
Door knob
Grosser Knopf



Métropolis

Cristal noir / Black crystal / Schwarzer Kristall

- 1 Bouton grand modèle / Door knob / Grosser Knopf
L'unité / Per piece / ProStück - Ref. A11.639V/A2L
La paire / Per pair / Das Paar - Ref. A11.638V/A2L

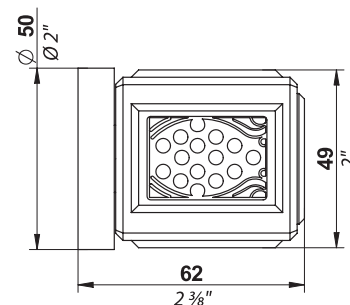

- 2 Poignée de porte
Door handle
Türknopf



Métropolis

Cristal noir / Black crystal / Schwarzer Kristall

- 2 Poignée de porte - Carré de 7 & 8 mm
Door handle - 7 & 8mm spindle / Türknopf - Stift 7 & 8 mm
L'unité / Per piece / ProStück - Ref. A11.639/A2L
La paire / Per pair / Das Paar - Ref. A11.638/A2L



Samoa

Bouton moyen modèle
Medium size cabinet knob
Mittelgrosser Knopf

Cristal clair / Clear crystal / Klarer Kristall
Ref. A11.26BP/A2F

Cristal noir / Black crystal / Schwarzer Kristall
Ref. A11.26BP/A2N

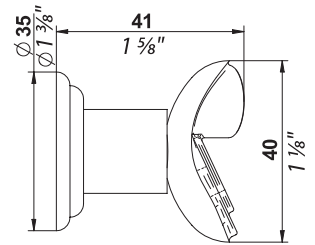

Thaïs

Bouton moyen modèle
Medium size cabinet knob
Mittelgrosser Knopf

Cristal clair / Clear crystal / Klarer Kristall
Ref. A11.26BP/A2E

Cristal noir / Black crystal / Schwarzer Kristall
Ref. A11.26BP/A2P

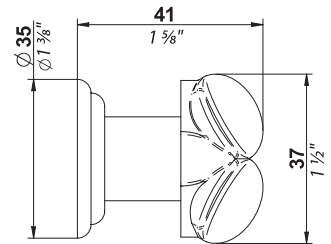

Cactus

Bouton moyen modèle
Medium size cabinet knob
Mittelgrosser Knopf
Ref. A11.26BP/A2C

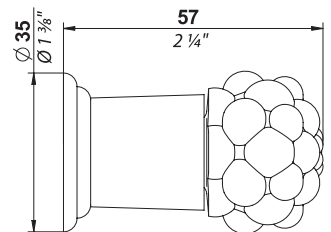



Profil Cristal LALIQUE

Bouton moyen modèle
Medium size cabinet knob
Mittelgrosser Knopf

Cristal clair / Clear crystal / Klarer Kristall
Ref. A I I .26BP/A6G

Cristal noir / Black crystal / Schwarzer Kristall
Ref. A I I .26BP/A6L

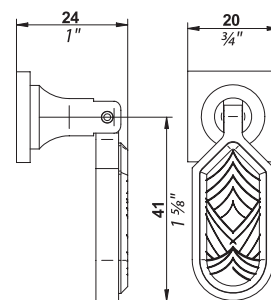

Profil Cristal LALIQUE

Cristal clair / Clear crystal / Klarer Kristall

- ❶ Poignée fixe / Static handle / Statische Türklinke
L'unité / Per piece / ProStück - Ref. A I I .639V/A6H
La paire / Per pair / Das Paar - Ref. A I I .638V/A6H

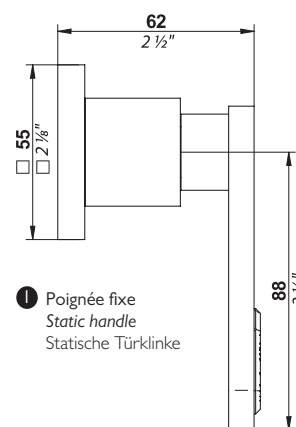

- ❶ Poignée fixe
Static handle
Statische Türklinke



Profil Cristal LALIQUE

Cristal clair / Clear crystal / Klarer Kristall

- ❷ Poignée de porte - Carré de 7 & 8 mm
Door handle - 7 & 8mm spindle
Türklinke - Stift 7 & 8 mm
L'unité / Per piece / ProStück - Ref. A I I .639/A6H
La paire / Per pair / Das Paar - Ref. A I I .638/A6H



Profil Cristal LALIQUE

Cristal noir / Black crystal / Schwarzer Kristall

- ❶ Poignée fixe / Static handle / Statische Türklinke
L'unité / Per piece / ProStück - Ref. A I I .639V/A6M
La paire / Per pair / Das Paar - Ref. A I I .638V/A6M

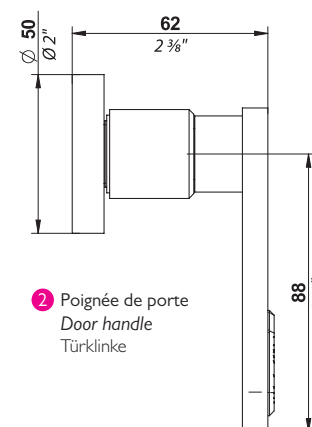

- ❷ Poignée de porte
Door handle
Türklinke



Profil Cristal LALIQUE

Cristal noir / Black crystal / Schwarzer Kristall

- ❷ Poignée de porte - Carré de 7 & 8 mm
Door handle - 7 & 8mm spindle
Türklinke - Stift 7 & 8 mm
L'unité / Per piece / ProStück - Ref. A I I .639/A6M
La paire / Per pair / Das Paar - Ref. A I I .638/A6M





Océania

Bouton grand modèle / Door knob / Grosser Knopf
L'unité / Per piece / ProStück - Ref. A11.639V/A2C
La paire / Per pair / Das Paar - Ref. A11.638V/A2C

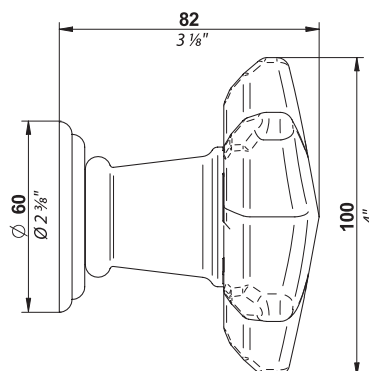

Panthère

Cristal clair / Clear crystal / Klarer Kristall

1 Bouton grand modèle / Door knob / Grosser Knopf
L'unité / Per piece / ProStück - Ref. A11.639V/A2H
La paire / Per pair / Das Paar - Ref. A11.638V/A2H

2 Poignée de porte - Carré de 7 & 8 mm
Door handle - 7 & 8mm spindle
Türknoopf - Stift 7 & 8 mm
L'unité / Per piece / ProStück - Ref. A11.639/A2H
La paire / Per pair / Das Paar - Ref. A11.638/A2H

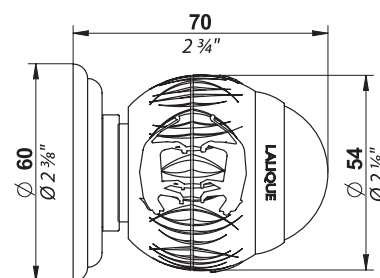

1 Bouton grand modèle
Door knob
Grosser Knopf



Panthère

Cristal noir / Black crystal / Schwarzer Kristall

1 Bouton grand modèle / Door knob / Grosser Knopf
L'unité / Per piece / ProStück - Ref. A11.639V/A2K
La paire / Per pair / Das Paar - Ref. A11.638V/A2K

2 Poignée de porte - Carré de 7 & 8 mm
Door handle - 7 & 8mm spindle
Türknoopf - Stift 7 & 8 mm
L'unité / Per piece / ProStück - Ref. A11.639/A2K
La paire / Per pair / Das Paar - Ref. A11.638/A2K

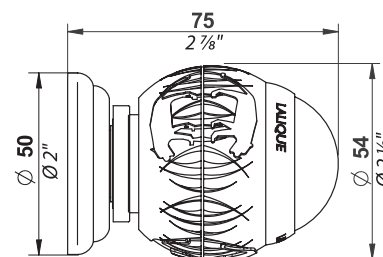

2 Poignée de porte
Door handle
Türknoopf

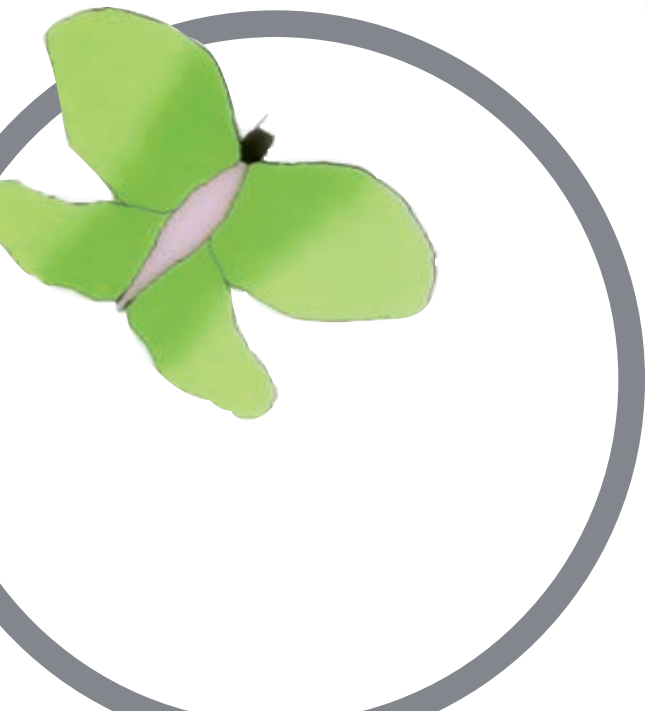
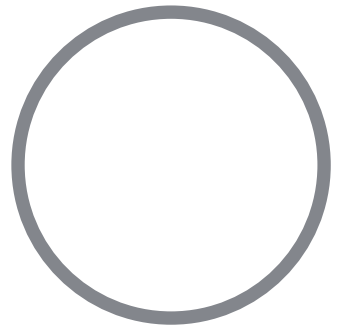
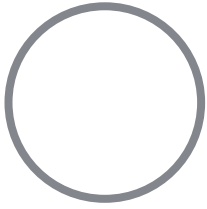



Collection
BERNARDAUD





Symbole de la tradition et du luxe, BERNARDAUD incarne l'une des formes les plus novatrices du savoir-faire français.

A symbol of tradition and luxury, BERNARDAUD embodies one of the most innovative forms of French know-how.

Als Sinnbild für Tradition und Luxus verkörpert BERNARDAUD eine der innovativsten Formen französischen Know-hows.

Née d'un savoir-faire artisanal profondément ancré dans la tradition française, l'alliance JCD Créations et Bernardaud célèbre le luxe sous toutes les formes d'un art sans cesse renouvelé.

The result of craft expertise profoundly steeped in French tradition, the alliance of JCD Créations and Bernardaud celebrates luxury in all its forms with constantly renewed artistry.

Das Bündnis zwischen JCD Créations und Bernardaud gründet auf einem tief in der französischen Tradition verwurzelten handwerklichen Können und steht im Zeichen einer neuen Kunst in all ihren Formen.



BERNARDAUD

Porcelainier d'exception...

Bernardaud, premier fabricant et exportateur de porcelaine de table en France, est aussi une entreprise familiale. Depuis 1863, les secrets et les techniques d'une culture deux fois millénaire s'y transmettent de père en fils. Bernardaud connaît l'alchimie et les gestes qui transforment la terre en une porcelaine d'une blancheur et d'une finesse incomparable, translucide et sonore. Il connaît les vertus du temps grâce auxquelles on élève un savoir-faire au rang d'art de vivre. Bernardaud s'identifie aujourd'hui à la marque qu'il a su créer et s'inscrit dans la lignée des grands noms qui contribuent au rayonnement de la France. Bernardaud fait partie des soixante-dix entreprises du Comité Colbert qui représentent à l'étranger l'industrie du luxe et la qualité française.

Exceptional porcelain-maker...

Bernardaud, France's leading manufacturer and exporter of table porcelain, is also a family business. Since 1863, the secrets and techniques of a two-thousand year old culture have been handed down from father to son. Bernardaud is a master of the alchemy and the gestures which transform clay into an incomparably white, fine porcelain ware, translucent and sonorous. It is well aware of the virtues of time which transforms know-how into the art of living. Today, Bernardaud is identified with the brand it created and forms part of the heritage of great names which contribute to France's renown. Bernardaud is one of the seventy companies of the Colbert Committee which represent the luxury industry and French quality abroad.

Der Ausnahme- Porzellanhersteller...

Die Firma Bernardaud, Frankreichs führender Hersteller und Exporteur von Tafelporzellan, wird als Familienunternehmen geführt. Seit 1863 werden Geheimnisse und Verfahren einer zweitausend Jahre alten Kultur von Vätern an Söhne weitergegeben. Bernardaud ist ein Meister der Alchemie und des Ausdrucks und verwandelt bloßen Ton in durchscheinendes, volltönendes Porzellan von unvergleichbarer weißer Feinheit. Bei Bernardaud weiß man um den Wert der Zeit, der Know-how zu Lebenskunst macht. Heute wird die Firma Bernardaud mit der von ihr geschaffenen Marke gleichgesetzt und gehört zum Vermächtnis großer Namen, die zu Frankreichs Renommee in der Branche beigetragen haben. Bernardaud ist eines der sieben Mitglieder des Comité Colbert, das Luxusgüter und französische Qualität im Ausland vertritt.





Passion

Bouton grand modèle / Door knob / Grosser Knopf
L'unité / Per piece / ProStück - Ref. A11.639V/A7C
La paire / Per pair / Das Paar - Ref. A11.638V/A7C

- ❶ Poignée de porte - Carré de 7 & 8 mm
Door handle - 7 & 8mm spindle
Türknoopf - Stift 7 & 8 mm
L'unité / Per piece / ProStück - Ref. A11.639/A7C
- ❷ La paire / Per pair / Das Paar - Ref. A11.638/A7C

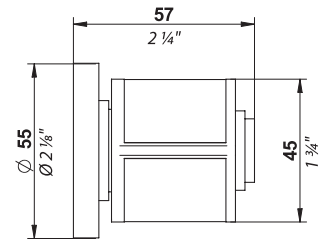

- ❶ Bouton grand modèle
Door knob
Grosser Knopf



Capucine

Papillon vert / Green butterfly / Grünem Schmetterling

- ❸ Bouton grand modèle / Door knob / Grosser Knopf
L'unité / Per piece / ProStück - Ref. A11.639V/A7E
La paire / Per pair / Das Paar - Ref. A11.638V/A7E

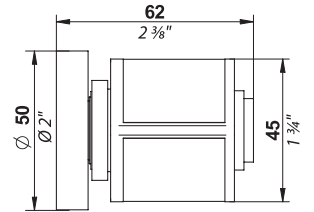

- ❷ Poignée de porte
Door handle
Türknoopf



Capucine

Papillon vert / Green butterfly / Grünem Schmetterling

- ❹ Poignée de porte - Carré de 7 & 8 mm
Door handle - 7 & 8mm spindle
Türknoopf - Stift 7 & 8 mm
L'unité / Per piece / ProStück - Ref. A11.639/A7E
La paire / Per pair / Das Paar - Ref. A11.638/A7E

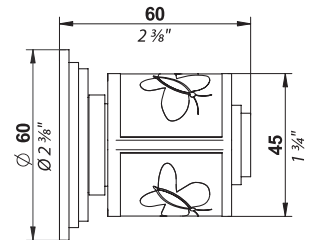

- ❸ Bouton grand modèle
Door knob
Grosser Knopf



Capucine

Papillon mauve / Mauve butterfly / Violettem Schmetterling

- ❸ Bouton grand modèle / Door knob / Grosser Knopf
L'unité / Per piece / ProStück - Ref. A11.639V/A7D
La paire / Per pair / Das Paar - Ref. A11.638V/A7D

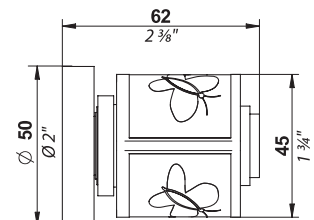

- ❹ Poignée de porte
Door handle
Türknoopf



Capucine

Papillon mauve / Mauve butterfly / Violettem Schmetterling

- ❹ Poignée de porte - Carré de 7 & 8 mm
Door handle - 7 & 8mm spindle
Türknoopf - Stift 7 & 8 mm
L'unité / Per piece / ProStück - Ref. A11.639/A7D
La paire / Per pair / Das Paar - Ref. A11.638/A7D



Ithaque

Décor platine / Door knob / Platin- Dekor

- 1 Bouton grand modèle / Platinum decor / Grosser Knopf
L'unité / Per piece / ProStück - Ref. A11.639V/A7B
La paire / Per pair / Das Paar - Ref. A11.638V/A7B
- 2 Poignée de porte - Carré de 7 & 8 mm
Door handle - 7 & 8mm spindle
Türknohf - Stift 7 & 8 mm
L'unité / Per piece / ProStück - Ref. A11.639/A7B
La paire / Per pair / Das Paar - Ref. A11.638/A7B

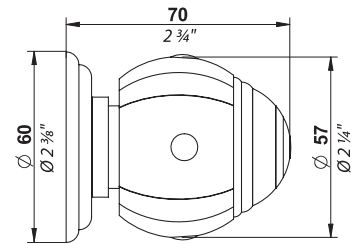

1 Bouton grand modèle
Door knob
Grosser Knopf



Ithaque

Décor doré / Gold decor / Gold- Dekor

- 1 Bouton grand modèle / Door knob / Grosser Knopf
L'unité / Per piece / ProStück - Ref. A11.639V/A7A
La paire / Per pair / Das Paar - Ref. A11.638V/A7A
- 2 Poignée de porte - Carré de 7 & 8 mm
Door handle - 7 & 8mm spindle
Türknohf - Stift 7 & 8 mm
L'unité / Per piece / ProStück - Ref. A11.639/A7A
La paire / Per pair / Das Paar - Ref. A11.638/A7A

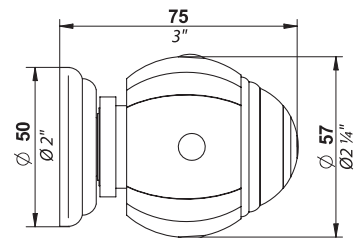

2 Poignée de porte
Door handle
Türknohf



Marquise

Décor platine / Platinum decor / Platin- Dekor

- 1 Bouton grand modèle / Door knob / Grosser Knopf
L'unité / Per piece / ProStück - Ref. A11.639V/A7G
La paire / Per pair / Das Paar - Ref. A11.638V/A7G
- 2 Poignée de porte - Carré de 7 & 8 mm
Door handle - 7 & 8mm spindle / Türknohf - Stift 7 & 8 mm
L'unité / Per piece / ProStück - Ref. A11.639/A7G
La paire / Per pair / Das Paar - Ref. A11.638/A7G

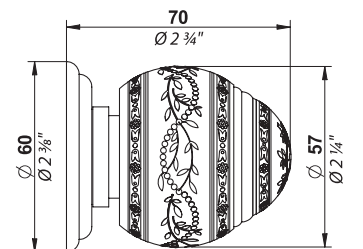

1 Bouton grand modèle
Door knob
Grosser Knopf



Marquise

Décor doré / Gold decor / Gold- Dekor

- 1 Bouton grand modèle / Door knob / Grosser Knopf
L'unité / Per piece / ProStück - Ref. A11.639V/A7F
La paire / Per pair / Das Paar - Ref. A11.638V/A7F
- 2 Poignée de porte - Carré de 7 & 8 mm
Door handle - 7 & 8mm spindle / Türknohf - Stift 7 & 8 mm
L'unité / Per piece / ProStück - Ref. A11.639/A7F
La paire / Per pair / Das Paar - Ref. 638/A7F

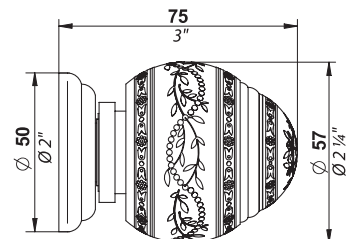

2 Poignée de porte
Door handle
Türknohf



Collection

AP

ALBERTO PINTO

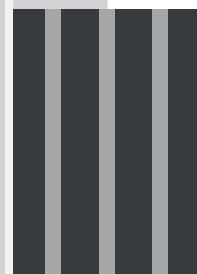

AP

ALBERTO PINTO



C'est en travaillant sur des projets communs, comme des yachts de luxe ou des villas prestigieuses, que THG, fabricant français de robinetterie et d'accessoires de salles de bains haut de gamme et le célèbre architecte d'intérieur Alberto Pinto se sont rencontrés. Très heureux de cette belle collaboration, M. Pinto, toujours en quête de nouveaux défis, a proposé à THG de réaliser une série de robinetterie.

Alberto Pinto a donc créé une série exclusive aux lignes fluides et au design épuré, nommée "Le II by Alberto Pinto", rappelant ainsi l'adresse mythique de l'hôtel particulier situé au cœur de Paris, à deux pas de la Place des Victoires où est installé son bureau d'architecture intérieure et de décoration.

It is through working on joint projects, such as luxurious yachts and prestigious villas that THG, a French top-end taps and bathroom accessory manufacturer and the well known interior designer, Alberto Pinto crossed paths. Delighted to be part of this venture, Mr. Pinto, who is always on the look out for new challenges, offered to create a range of taps and fittings for THG.

Alberto Pinto has created an exclusive range with flowing lines and a sophisticated design entitled "Le II by Alberto Pinto"; evoking the mythical address of the town house located in central Paris - just a stone's throw from the Place des Victoires - where Pinto has set up his interior design and decoration studio.

Bei gemeinsamen Projekten wie Luxusyachten oder Villen kreuzten sich die Wege des berühmten Innenarchitekten Alberto Pinto und THG Paris dem französischen Hersteller hochwertiger Badezimmerarmaturen und -accessoires. Immer auf der Suche nach neuen Herausforderungen und erfreut über die gute Zusammenarbeit, schlug Alberto Pinto vor, eine Armaturensérie für THG Paris zu entwerfen.

Alberto Pinto gestaltete eine exklusive dabei puristische Kollektion mit fließenden Formen. „Le II by Alberto Pinto“ spielt mit der legendären Adresse seines Pariser Design Studios und Showrooms, unweit vom Place des Victoires.



Le II by Alberto Pinto

Bouton petit modèle
Small size cabinet knob
Kleiner Knopf
Ref. A11.26BT/U2A

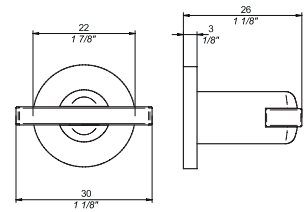

Le II by Alberto Pinto

Bouton moyen modèle
Medium size cabinet knob
Mittelgrosser Knopf
Ref. A11.26BP/U2A

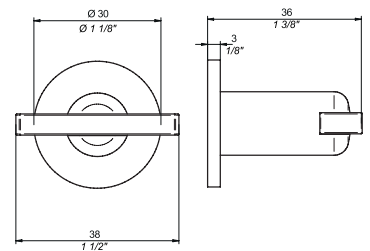

Le II by Alberto Pinto

Bouton grand modèle / Door knob / Grosser Knopf
L'unité / Per piece / ProStück - Ref. A11.639V/U2A
La paire / Per pair / Das Paar - Ref. A11.638V/U2A

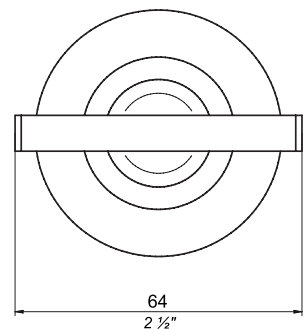
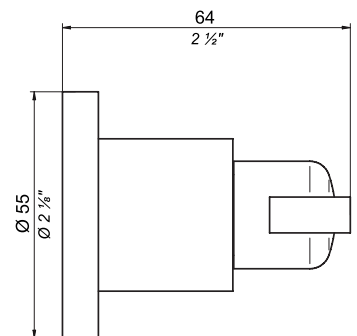





Collection
Pierre-Yves ROCHON





PYR

Pierre-Yves ROCHON

D'origine bretonne, Pierre-Yves Rochon a vécu toute sa jeunesse dans de nombreux pays étrangers, ce qui a aiguisé sa curiosité du monde et donné une ouverture d'esprit à tous les courants culturels et artistiques.

Après avoir hésité entre la musique et le cinéma, il a finalement opté pour des études aux Beaux-Arts et choisi la décoration et l'architecture d'intérieur.

Avant d'ouvrir son propre cabinet à 30 ans, il a travaillé pour de grandes enseignes, chez des décorateurs contemporains, expérimentant ainsi toutes les tendances et tous les styles, du plus classique au plus futuriste.

Ses premières réalisations (souvent sur concours) se sont réparties entre bureaux, appartements, maisons et surtout l'hôtel des «Crayères» à Reims, qui sera le début d'une vraie conquête de l'univers hôtelier et plus particulièrement la grande hôtellerie internationale de luxe.

En 2005, Pierre-Yves Rochon a associé son savoir-faire à celui de THG afin de développer une collection complète de robinetteries et d'accessoires dans un style très raffiné.

Born in Brittany, Pierre-Yves Rochon spent his childhood in numerous foreign countries, which sharpened his interest for the world and gave him an open-mindedness regarding all the cultural and artistic trends.

After wavering between music and cinema, he finally made up his mind and entered art school and chose interior decoration and architecture.

Before opening his office proper at 30 years old, he worked for well-known brand-names, for contemporary decorators where he could test all the trends and styles from the most classical to the most futurist.

His first creations - often under competition - were shared between offices, flats, houses and especially the famous "Crayères" Hotel in Reims, which would be the beginning of a real conquest of the hotel trade and more particularly of the prestigious international hotels.

In 2005, Pierre-Yves Rochon gathered his know-how to THG's in order to offer you a complete collection of fittings and accessories in a very refined style.

Pierre -Yves Rochon, ein Bretoner im Original, bereiste schon in seiner Jugend unzählige Länder. Dies weckte seine Neugier auf die Welt und öffnete ihm die Sicht auf vielfältige kulturelle und künstlerische Strömungen.

Zwischen einer Karriere in der Filmbranche und der Musik schwankend, entschied er sich letztendlich für die Kunst: Er studierte an der Kunstakademie Innenarchitektur und Interior-Design.

Bevor er mit dreißig Jahren sein eigenes Unternehmen gründete, arbeitete er für große Namen in der Branche, sowie für bekannte Interior- Designer und machte sich von der Klassik bis zum Purismus mit allen Stilrichtungen vertraut.

Seine ersten Kreationen (oft in Wettbewerben ausgezeichnet) zieren Büros, Wohnungen, Häuser und vor allem das Hotel "Crayères" in Reims, was ein Sprungbett zu einer steilen Karriere als Interior-Designer in der Hotelbranche (vor allem der internationalen Luxus- Hotellerie) bedeutet.

Im Jahr 2005 begann seine Kooperation mit THG. Als Resultat stellte er in Zusammenarbeit mit uns eine komplette Armaturen-Kollektion mit Accessoires in einem aufregend neuen exklusiven Stil vor.



1 2



3



4

Quelques réalisations de Pierre-Yves Rochon
Some Pierre-Yves Rochon creations
Einige Pierre-Yves Rochon Kreationen

- 1 - Intercontinental - Paris
- 2 - Les «Crayères» - Reims
- 3 - Le Keppler - Paris
- 4 - Monte Carlo Bay - Monaco
- 5 - Hôtel du lac - Vevey - Suisse
- 6 - Hermitage - Monaco



5

6







Faubourg

Métal / Metal / Metall

Bouton grand modèle / Door knob / Grosser Knopf
L'unité / Per piece / ProStück - Ref. A11.639V/G2T
La paire / Per pair / Das Paar - Ref. A11.638V/G2T



Faubourg

Porcelaine blanche / White porcelain / Weiss- Porzellan

Bouton grand modèle / Door knob / Grosser Knopf
L'unité / Per piece / ProStück - Ref. A11.639V/G2K
La paire / Per pair / Das Paar - Ref. A11.638V/G2K



Faubourg

Porcelaine noire / Black porcelain / Schwarz- Porzellan

Bouton grand modèle / Door knob / Grosser Knopf
L'unité / Per piece / ProStück - Ref. A11.639V/G2L
La paire / Per pair / Das Paar - Ref. A11.638V/G2L



Frivole

Bouton grand modèle / Door knob / Grosser Knopf
L'unité / Per piece / ProStück - Ref. A11.639V/G2R
La paire / Per pair / Das Paar - Ref. A11.638V/G2R



Froufrou

Bouton grand modèle / Door knob / Grosser Knopf
L'unité / Per piece / ProStück - Ref. A11.639V/G2N
La paire / Per pair / Das Paar - Ref. A11.638V/G2N

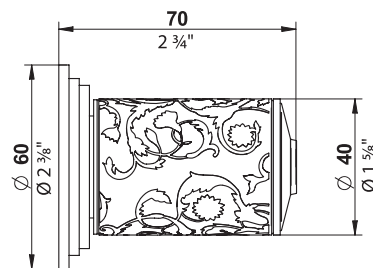
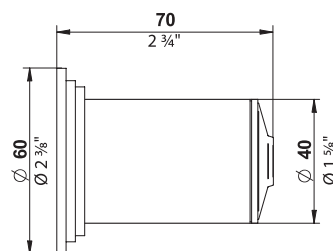





Collection

 **JAMIE DRAKE**





JAMIE DRAKE

Jamie Drake, le célèbre designer d'intérieur new-yorkais, partage la pensée de l'écrivain Jean Cocteau sur la nécessité de ne pas confondre l'importance et la gravité. Reconnu et très apprécié dans le monde entier, Jamie Drake est à l'aise aussi bien dans le style classique que dans le contemporain, avec un don tout particulier pour la décoration d'intérieur. Pour créer son style brillant et signé, Jamie Drake se complait à utiliser les couleurs, à mélanger les styles et les époques et à façonner les intérieurs à l'image de leurs résidents. L'audace, le raffinement, l'assurance, la douceur et l'humour : tels sont les ingrédients de sa potion magique. Ses clients occupent des professions allant du monde du spectacle à la politique (de Madonna à Michael Bloomberg). Jamie Drake participe régulièrement à la réalisation des maisons témoins les plus prestigieuses des Etats-Unis.

Jamie Drake est l'un des principaux lanceurs de tendance dans le monde du design. Ses réalisations ont été très largement publiées dans des grands magazines tels que Elle Décor, Architectural Digest (USA, France, Allemagne), House Beautiful ainsi que The New York Times, House & Garden et Metropolitan Home. Il a d'ailleurs été récemment intégré au «Interior design Hall of Fame». Jamie Drake, parmi d'autres, s'est également vu attribuer la distinction de Designer International de l'année. La maison d'édition Bulfinch Press a publié un livre sur sa vision personnelle de l'esthétisme en 2005 intitulé : «Jamie Drake's new American Glamour».

"It's important," as Jean Cocteau once said, "not to confuse seriousness with gravity." Famed designer Jamie Drake, a New York based style icon, echoes this sentiment with his innovative taste and unique design. Internationally recognized and highly celebrated, Drake is a true master in both traditional and contemporary styles with a natural gift for designing brilliantly stylized modern interiors. To create his signature look, Drake embraces an eclectic mix of styles, colors and periods, fashioning uncommonly alluring interiors that express the individual personalities of their occupants. Bold, polished, confident, suave and witty: these are the ingredients in his potent brew. With clients spanning the entire human spectrum, Drake has crafted custom looks for entertainers such as Madonna, to politicians including Michael Bloomberg. His client base reflects the alluring adaptability of his designs.

Drake is one of the foremost tastemakers on the design scene and he frequently participates in some of the most prestigious show houses. His work has been widely published in several of the industry's leading journals including, Elle Decor, Architectural Digest (US, France, Germany) House Beautiful, Metropolitan Home, House & Garden as well as the New York Times. A recent inductee of the Interior Design Hall of Fame, Drake recently received the Andrew Martin International interior Designer of the Year award, and maintains numerous other accolades. "Jamie Drake's New American Glamour," a book on his personal aesthetic, was published by Bulfinch Press in 2005.



Jean Cocteau hat ein Mal gesagt: „Man darf Ernsthaftigkeit nicht mit Schwere verwechseln.“ Jamie Drake, berühmter Designer und New Yorker Stilikone, verkörpert dieses Gefühl in seinem innovativem Geschmack und einzigartigem Design. Als Empfänger zahlreicher internationaler Auszeichnungen und Ehrungen beherrscht Drake sowohl den traditionellen als auch den zeitgenössischen Stil und verfügt über die natürliche Gabe der Ausgestaltung brillant stilisierter moderner Interieurs. Um diesen ihm eigenen Look zu entwickeln, greift Drake auf eine vielseitige Mischung aus Stilen, Farben und Perioden zurück und gestaltet seine ungewöhnlich verführerischen Innenräume, die Ausdruck der Persönlichkeit ihrer Bewohner sind. Seine überzeugenden Kreationen braut er zusammen aus Wagemut, Schliff, Selbstvertrauen, Sanftheit und Witz. Zu Drakes Kunden zählt das gesamte menschliche Spektrum; er ist verantwortlich für die Looks von Stars wie Madonna bis hin zu Politikern wie Michael Bloomberg. Sein Kundentamm spiegelt die reizvolle Anpassungsfähigkeit seiner Designs wider.

Drake gehört zu den führenden Stilprägnern der Designszene und ist häufig in den prestigeträchtigsten Schauhäusern zu sehen. Seine Arbeiten wurden in vielen der führenden Branchenmagazine, wie Elle Décor, Architectural Digest (USA, Frankreich, Deutschland), House Beautiful, Metropolitan Home, House & Garden, sowie in der New York Times veröffentlicht. Kürzlich wurde Jamie Drake in die Interior Design Hall of Fame aufgenommen und mit dem Andrew Martin International Interior Designer of the Year Award und zahlreichen weiteren Auszeichnungen geehrt. 2005 erschien „Jamie Drake's New American Glamour“, ein Buch über seine ganz persönliche Ästhetik, bei Bulfinch Press.





Profil

Onyx noir / Black onyx / Schwarz Onyx

- 1 Poignée fixe / Static handle / Statische Türklinke
L'unité / Per piece / ProStück - Ref. A11.639V/A6P
La paire / Per pair / Das Paar - Ref. A11.638V/A6P



Profil

Onyx noir / Black onyx / Schwarz Onyx

- 2 Poignée de porte - Carré de 7 & 8 mm
Door handle - 7 & 8mm spindle
Türklinke - Stift 7 & 8 mm
L'unité / Per piece / ProStück - Ref. A11.639V/A6P
La paire / Per pair / Das Paar - Ref. A11.638V/A6P

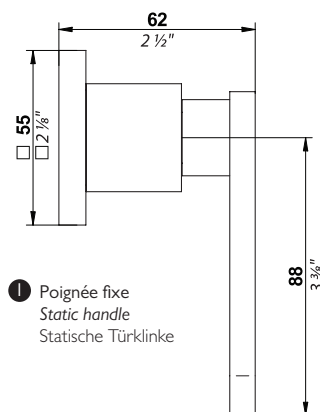

Profil

- 1 Poignée fixe / Static handle / Statische Türklinke
L'unité / Per piece / ProStück - Ref. A11.639V/A6B
La paire / Per pair / Das Paar - Ref. A11.638V/A6B

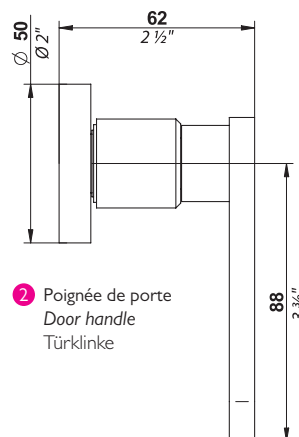

Profil

- 2 Poignée de porte - Carré de 7 & 8 mm
Door handle - 7 & 8mm spindle
Türklinke - Stift 7 & 8 mm
L'unité / Per piece / ProStück - Ref. A11.639/A6B
La paire / Per pair / Das Paar - Ref. A11.638/A6B





Quand la modernité et la pureté des lignes
procurent une totale sensation de bien-être.

*When modernity and pure lines
give an absolute feeling of well-being.*

Wenn moderne Linien
ein absolutes Wellness-Gefühl geben.





Cubica

Bouton petit modèle
Small size cabinet knob
Kleiner Knopf
Ref. A11.26BT/G79

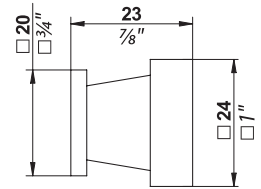

Cubica

Bouton moyen modèle
Medium size cabinet knob
Mittelgrosser Knopf
Ref. A11.26BP/G79

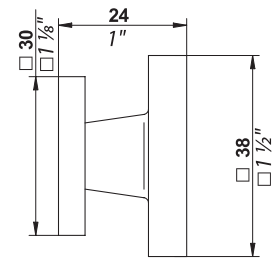

Cubica

- 1 Bouton grand modèle / Door knob / Grosser Knopf
L'unité / Per piece / ProStück - Ref. A11.639V/G79
La paire / Per pair / Das Paar - Ref. A11.638V/G79

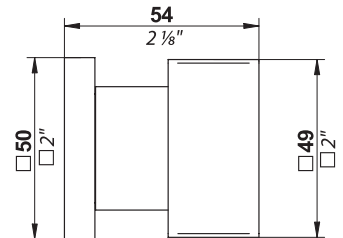

- 1 Bouton grand modèle
Door knob
Grosser Knopf



Cubica

- 2 Poignée de porte - Carré de 7 & 8 mm
Door handle - 7 & 8mm spindle
Türknoopf - Stift 7 & 8 mm
L'unité / Per piece / ProStück - Ref. A11.639V/G79
La paire / Per pair / Das Paar - Ref. A11.638V/G79

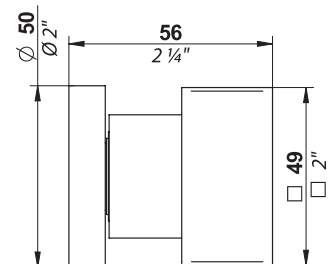

- 2 Poignée de porte
Door handle
Türknoopf



Pullman

Bouton petit modèle
Small size cabinet knob
Kleiner Knopf
Ref. A11.26BT/J06

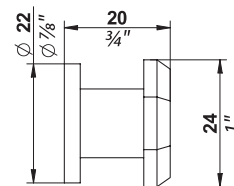

Pullman

Bouton moyen modèle
Medium size cabinet knob
Mittelgrosser Knopf
Ref. A11.26BP/J06

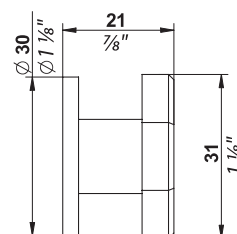

Pullman

- ❶ Bouton grand modèle / Door knob / Grosser Knopf
L'unité / Per piece / ProStück - Ref. A11.639V/J06
La paire / Per pair / Das Paar - Ref. A11.638V/J06

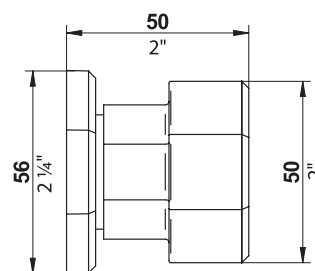

- ❶ Bouton grand modèle
Door knob
Grosser Knopf



Pullman

- ❷ Poignée de porte - Carré de 7 & 8 mm
Door handle - 7 & 8mm spindle
Türknohf - Stift 7 & 8 mm
L'unité / Per piece / ProStück - Ref. A11.639/J06
La paire / Per pair / Das Paar - Ref. A11.638/J06

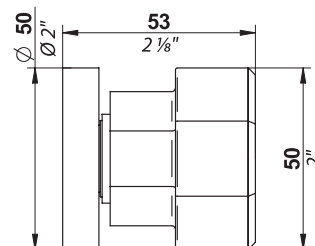

- ❷ Poignée de porte
Door handle
Türknohf



Diplomate lisse

Bouton petit modèle
Small size cabinet knob
Kleiner Knopf
Ref. A I I.26BT/U4A

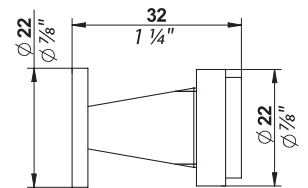

Diplomate lisse

Bouton moyen modèle
Medium size cabinet knob
Mittelgrosser Knopf
Ref. A I I.26BP/U4A

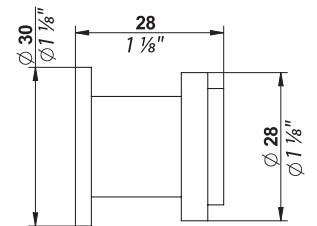

Diplomate lisse

- 1 Bouton grand modèle / Door knob / Grosser Knopf
L'unité / Per piece / ProStück - Ref. A I I.639V/U4A
La paire / Per pair / Das Paar - Ref. A I I.638V/U4A
- 2 Poignée de porte - Carré de 7 & 8 mm
Door handle - 7 & 8mm spindle
Türknoopf - Stift 7 & 8 mm
L'unité / Per piece / ProStück - Ref. A I I.639/U4A
La paire / Per pair / Das Paar - Ref. A I I.638/U4A

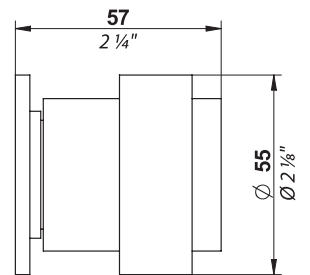

- 1 Bouton grand modèle
Door knob
Grosser Knopf

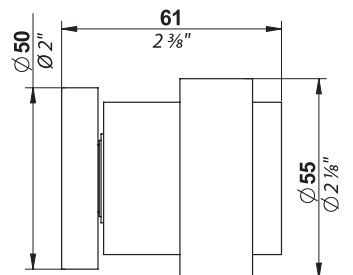

- 2 Poignée de porte
Door handle
Türknoopf



Diplomate annelée

Bouton petit modèle
Small size cabinet knob
Kleiner Knopf
Ref. A11.26BT/U4B

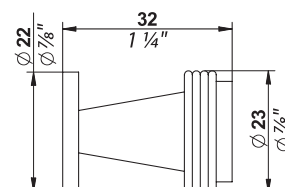

Diplomate annelée

Bouton moyen modèle
Medium size cabinet knob
Mittelgrosser Knopf
Ref. A11.26BP/U4B

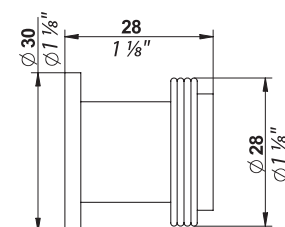

Diplomate annelée

1 Bouton grand modèle / Door knob / Grosser Knopf
L'unité / Per piece / ProStück - Ref. A11.639V/U4B
La paire / Per pair / Das Paar - Ref. A11.638V/U4B

2 Poignée de porte - Carré de 7 & 8 mm
Door handle - 7 & 8mm spindle
Türknoopf - Stift 7 & 8 mm
L'unité / Per piece / ProStück - Ref. A11.639/U4B
La paire / Per pair / Das Paar - Ref. A11.638/U4B

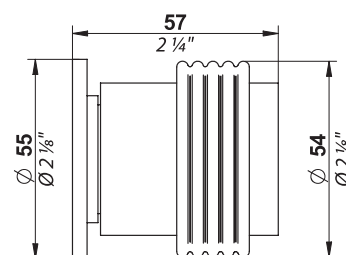

1 Bouton grand modèle
Door knob
Grosser Knopf

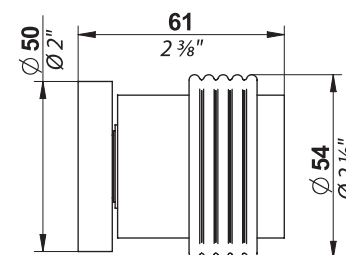

2 Poignée de porte
Door handle
Türknoopf



Charleston

Bouton petit modèle
Small size cabinet knob
Kleiner Knopf
Ref. A11.26BT/G29

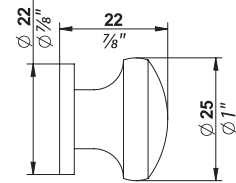

Charleston

Bouton moyen modèle
Medium size cabinet knob
Mittelgrosser Knopf
Ref. A11.26BP/G29

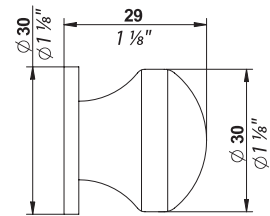

Alto

Bouton petit modèle
Small size cabinet knob
Kleiner Knopf
Ref. A11.26BT/G62

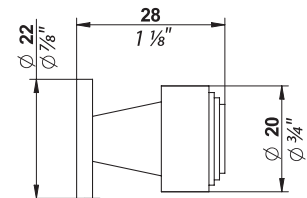

Alto

Bouton moyen modèle
Medium size cabinet knob
Mittelgrosser Knopf
Ref. A11.26BP/G62

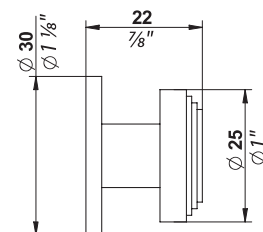



Jaipur Métal

- ❶ Bouton grand modèle / Door knob / Grosser Knopf
L'unité / Per piece / ProStück - Ref. A11.639V/A9F
La paire / Per pair / Das Paar - Ref. A11.638V/A9F
- ❷ Poignée de porte - Carré de 7 & 8 mm
Door handle - 7 & 8mm spindle
Türknoopf - Stift 7 & 8 mm
L'unité / Per piece / ProStück - Ref. A11.639/A9F
La paire / Per pair / Das Paar - Ref. A11.638/A9F

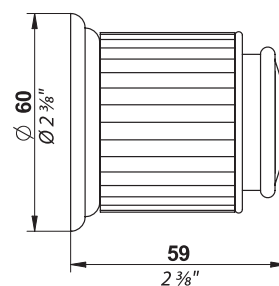

- ❶ Bouton grand modèle
Door knob
Grosser Knopf

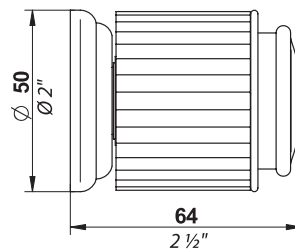

- ❷ Poignée de porte
Door handle
Türknoopf

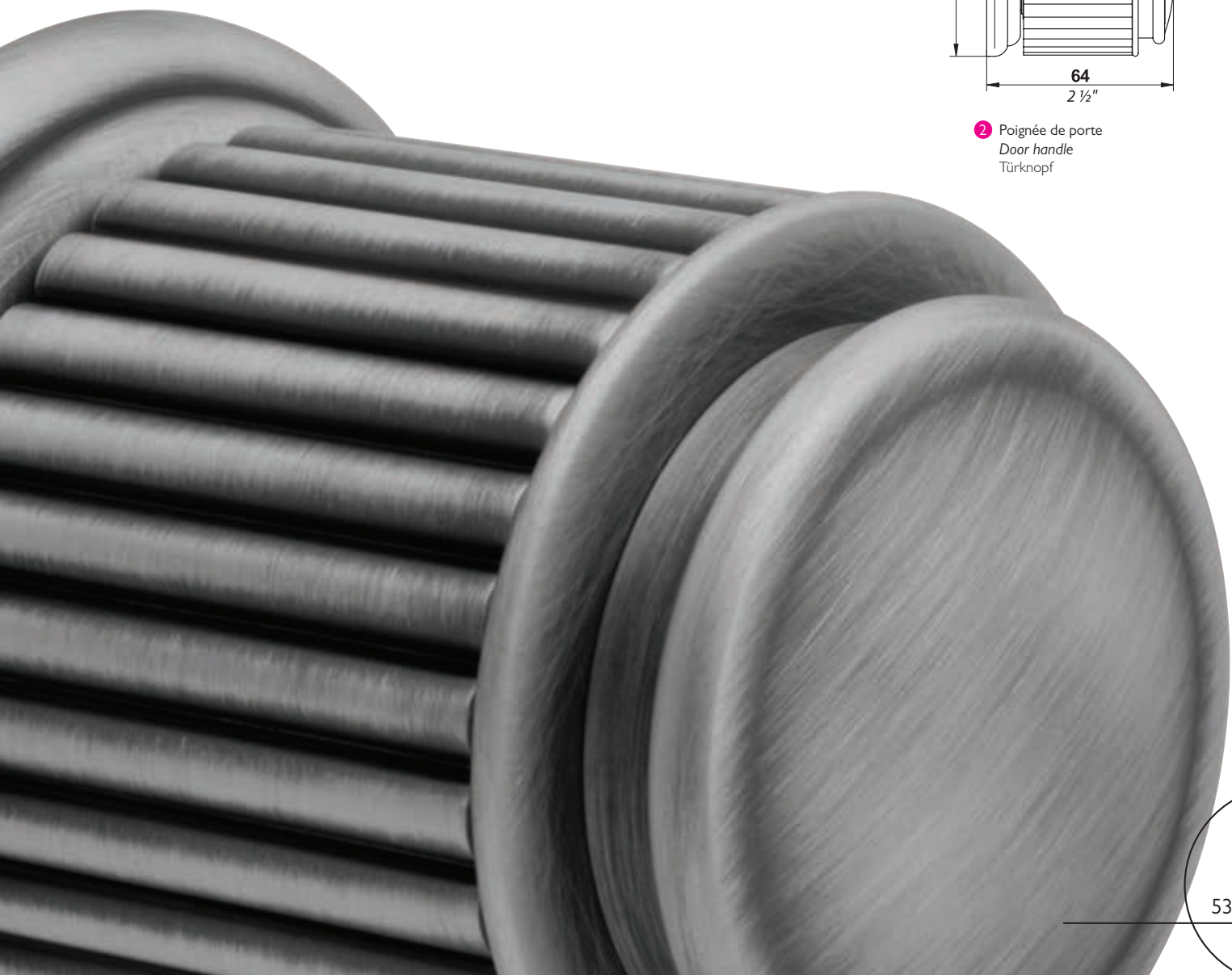

CONTEMPORAINE
SHAO - TANGO



Shao

- 1 Poignée fixe / Static handle / Statische Türklinke
L'unité / Per piece / ProStück - Ref. A11.639V/GIW
La paire / Per pair / Das Paar - Ref. A11.638V/GIW

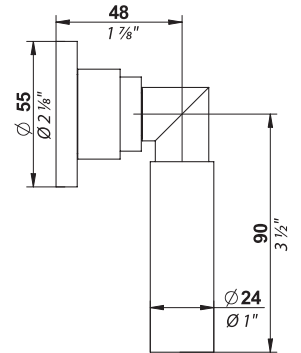

- 1 Poignée fixe
Static handle
Statische Türklinke



Shao

- 2 Poignée de porte - Carré de 7 & 8 mm
Door handle - 7 & 8mm spindle
Türklinke - Stift 7 & 8 mm
L'unité / Per piece / ProStück - Ref. A11.639/GIW
La paire / Per pair / Das Paar - Ref. A11.638/GIW

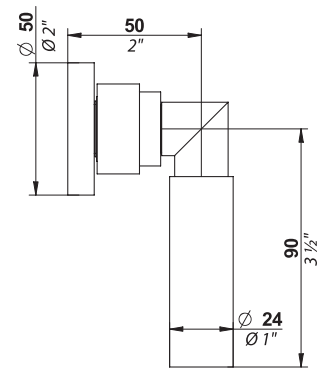

- 2 Poignée de porte
Door handle
Türklinke

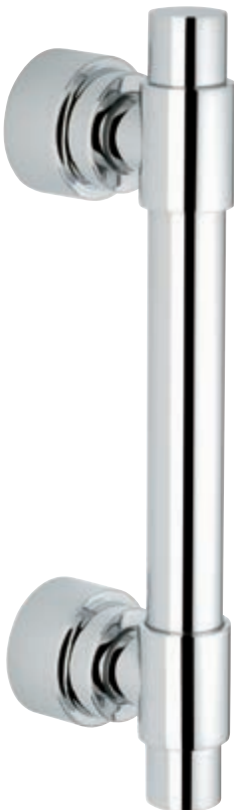

Tango

- Paire de poignées
Set of 2 door handles
Stangengriff als Paar
La paire / Per pair / Das Paar - Ref. A11.637V/G50

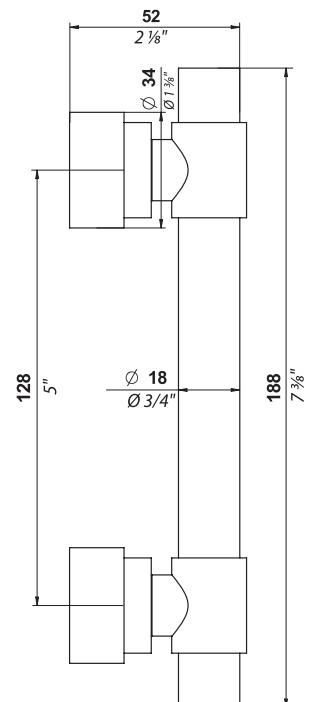



Mercure

Poignée de porte - Carré de 7 & 8 mm
Door handle - 7 & 8mm spindle
Türklinke -Stift 7 & 8 mm
L'unité / Per piece / ProStück - Ref. A11.639/A11
La paire / Per pair / Das Paar - Ref. A11.638/A11

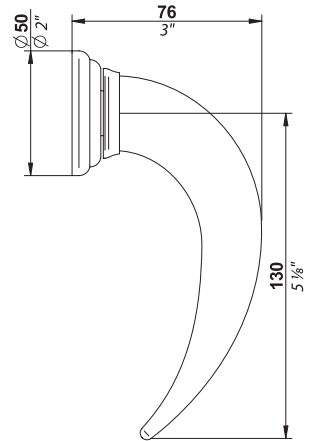

Eden

Poignée de porte - Carré de 7 & 8 mm
Door handle - 7 & 8mm spindle
Türklinke - Stift 7 & 8 mm
L'unité / Per piece / ProStück - Ref. A11.639/J40
La paire / Per pair / Das Paar - Ref. A11.638/J40

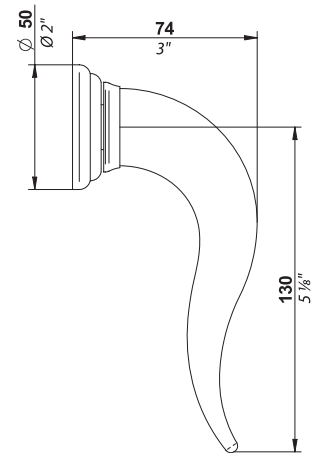

Cotton

Poignée de porte - Carré de 7 & 8 mm
Door handle - 7 & 8mm spindle
Türklinke- Stift 7 & 8 mm
L'unité / Per piece / ProStück - Ref. A11.639/J56
La paire / Per pair / Das Paar - Ref. A11.638/J56

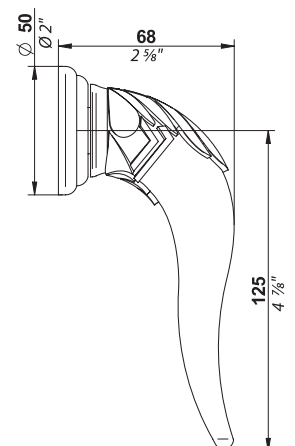



Quand les éclats de lumière
révèlent une beauté étincelante.

When light brilliance reveals a glittering beauty.

Wenn brillantes Licht die glänzende Schönheit enthüllt.





Mandarine Cristal

Bouton petit modèle
Small size cabinet knob
Kleiner Knopf

Cristal clair / *Clear crystal* / Klarer Kristall
Ref. A11.26BT/UID

Cristal satiné / *Satin crystal* / Kristall satiniert
Ref. A11.26BT/UIE

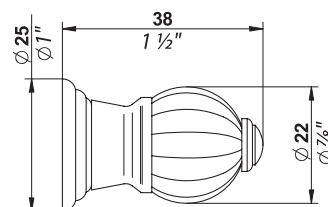

Mandarine Cristal

Bouton moyen modèle
Medium size cabinet knob
Mittelgrosser Knopf

Cristal clair / *Clear crystal* / Klarer Kristall
Ref. A11.26BP/UID

Cristal satiné / *Satin crystal* / Kristall satiniert
Ref. A11.26BP/UIE

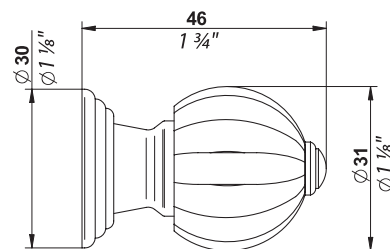



Mandarine Cristal

Cristal clair / Clear crystal / Klarer Kristall

- 1 Bouton grand modèle / Door knob / Grosser Knopf
L'unité / Per piece / ProStück - Ref. A11.639V/UID
La paire / Per pair / Das Paar - Ref. A11.638V/UID



Mandarine Cristal

Cristal clair / Clear crystal / Klarer Kristall

- 2 Poignée de porte - Carré de 7 & 8 mm
Door handle - 7 & 8mm spindle
Türknohf - Stift 7 & 8 mm
L'unité / Per piece / ProStück - Ref. A11.639/UID
La paire / Per pair / Das Paar - Ref. A11.638/AID

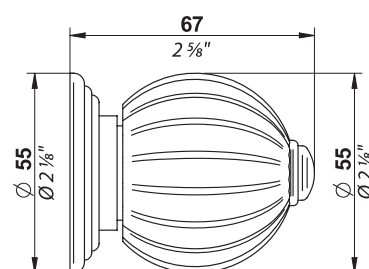

- 1 Bouton grand modèle
Door knob
Grosser Knopf



Mandarine Cristal

Cristal satiné / Satin crystal / Kristall satiniert

- 1 Bouton grand modèle / Door knob / Grosser Knopf
L'unité / Per piece / ProStück - Ref. A11.639V/UIE
La paire / Per pair / Das Paar - Ref. A11.638V/UIE

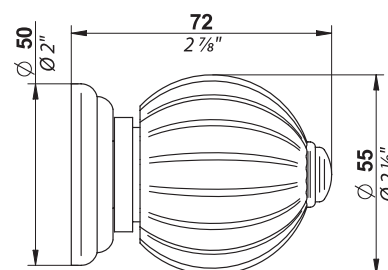

- 2 Poignée de porte
Door handle
Türknohf



Mandarine Cristal

Cristal satiné / Satin crystal / Kristall satiniert

- 2 Poignée de porte - Carré de 7 & 8 mm
Door handle - 7 & 8mm spindle
Türknohf - Stift 7 & 8 mm
L'unité / Per piece / ProStück - Ref. A11.639/UIE
La paire / Per pair / Das Paar - Ref. A11.638/UIE



Mandarine Cristal

Rosalin clair / Rosalin clear / Rosalin

- 1 Bouton grand modèle / Door knob / Grosser Knopf
L'unité / Per piece / ProStück - Ref. A11.639V/UIF
La paire / Per pair / Das Paar - Ref. A11.638V/UIF



Mandarine Cristal

Rosalin clair / Rosalin clear / Rosalin

- 2 Poignée de porte - Carré de 7 & 8 mm
Door handle - 7 & 8mm spindle
Türknohf - Stift 7 & 8 mm
L'unité / Per piece / ProStück - Ref. A11.639/UIF
La paire / Per pair / Das Paar - Ref. A11.638/UIF

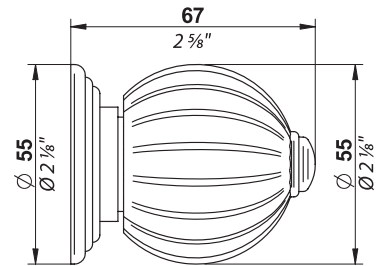

- 1 Bouton grand modèle
Door knob
Grosser Knopf



Mandarine Cristal

Rosalin satiné / Rosalin satin / Rosalin satiniert

- 1 Bouton grand modèle / Door knob / Grosser Knopf
L'unité / Per piece / ProStück - Ref. A11.639V/UIG
La paire / Per pair / Das Paar - Ref. A11.638V/UIG

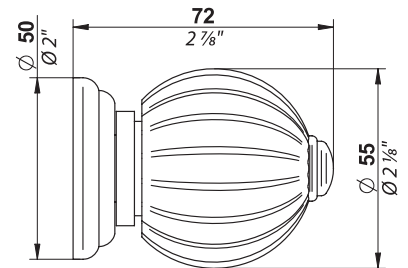

- 2 Poignée de porte
Door handle
Türknohf



Mandarine Cristal

Rosalin satiné / Rosalin satin / Rosalin satiniert

- 2 Poignée de porte - Carré de 7 & 8 mm
Door handle - 7 & 8mm spindle
Türknohf - Stift 7 & 8 mm
L'unité / Per piece / ProStück - Ref. A11.639/UIG
La paire / Per pair / Das Paar - Ref. A11.638/UIG



Mandarine Cristal

Saphir clair / *Sapphire clear* / Saphir

- ❶ Bouton grand modèle / *Door knob* / Grosser Knopf
L'unité / *Per piece* / ProStück - Ref. A11.639V/UIH
La paire / *Per pair* / Das Paar - Ref. A11.638V/UIH



Mandarine Cristal

Saphir clair / *Sapphire clear* / Saphir

- ❷ Poignée de porte - Carré de 7 & 8 mm
Door handle - 7 & 8mm spindle
Türkknopf - Stift 7 & 8 mm
L'unité / *Per piece* / ProStück - Ref. A11.639/UIH
La paire / *Per pair* / Das Paar - Ref. A11.638/UIH

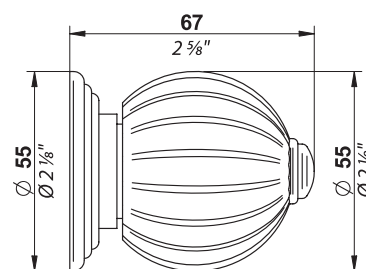

- ❶ Bouton grand modèle
Door knob
Grosser Knopf



Mandarine Cristal

Saphir satiné / *Sapphire satin* / Saphir satiniert

- ❶ Bouton grand modèle / *Door knob* / Grosser Knopf
L'unité / *Per piece* / ProStück - Ref. A11.639V/UIJ
La paire / *Per pair* / Das Paar - Ref. A11.638V/UIJ

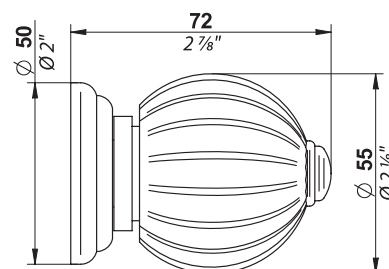

- ❷ Poignée de porte
Door handle
Türkknopf



Mandarine Cristal

Saphir satiné / *Sapphire satin* / Saphir satiniert

- ❷ Poignée de porte - Carré de 7 & 8 mm
Door handle - 7 & 8mm spindle
Türkknopf - Stift 7 & 8 mm
L'unité / *Per piece* / ProStück - Ref. A11.639/UIJ
La paire / *Per pair* / Das Paar - Ref. A11.638/UIJ



Mandarine Cristallia Diamant

Bouton petit modèle
Small size cabinet knob
Kleiner Knopf
Ref. A11.26BT/UIK

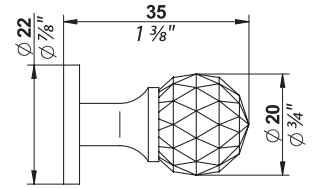

Mandarine Cristallia Diamant

Bouton moyen modèle
Medium size cabinet knob
Mittelgrosser Knopf
Ref. A11.26BP/UIK

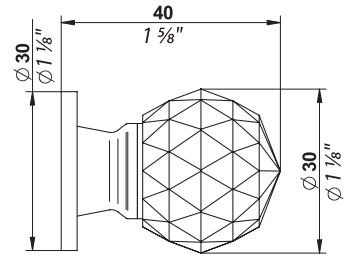

Mandarine Cristallia Diamant

Bouton grand modèle / Door knob / Grosser Knopf
L'unité / Per piece / ProStück - Ref. A11.639V/UIK
La paire / Per pair / Das Paar - Ref. A11.638V/UIK

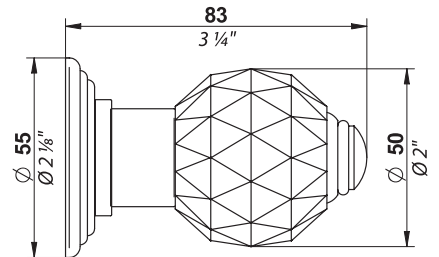

Mandarine Cristallia Diamant

Poignée de porte - Carré de 7 & 8 mm
Door handle - 7 & 8mm spindle
Türknoopf - Stift 7 & 8 mm
L'unité / Per piece / ProStück - Ref. A11.639/UIK
La paire / Per pair / Das Paar - Ref. A11.638/UIK

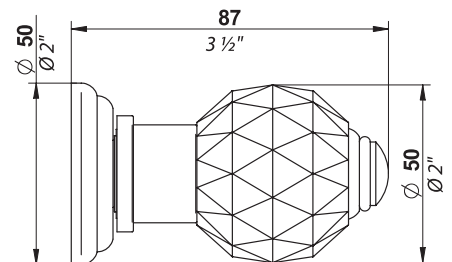



Diamant

Bouton petit modèle
Small size cabinet knob
Kleiner Knopf
Ref. A11.26BT/A11

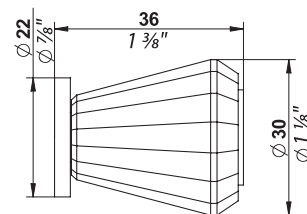

Diamant

Bouton moyen modèle
Medium size cabinet knob
Mittelgrosser Knopf
Ref. A11.26BP/A11

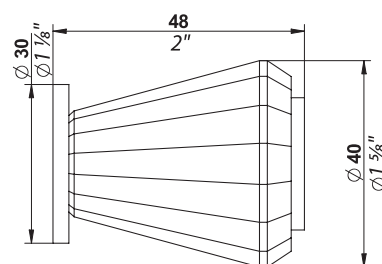

Luna

Bouton petit modèle
Small size cabinet knob
Kleiner Knopf
Ref. A11.26BT/G1X

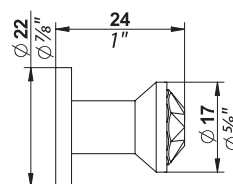

Luna

Bouton moyen modèle
Medium size cabinet knob
Mittelgrosser Knopf
Ref. A11.26BP/G1X

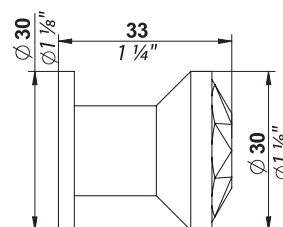

CRISTAL
ART DÉCO CRISTAL

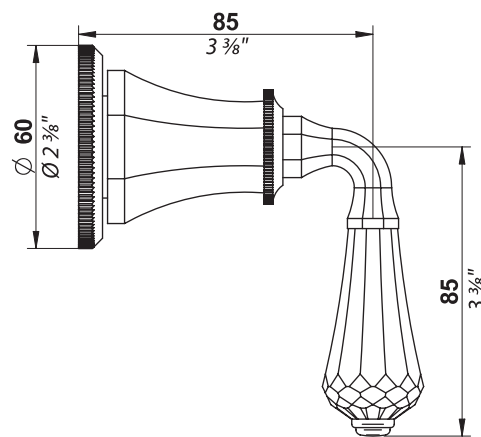

Art Déco Cristal

Poignée fixe

Static handle

Statische Türklinke

L'unité / Per piece / ProStück - Ref. A11.639V/A56

La paire / Per pair / Das Paar - Ref. A11.638V/A56

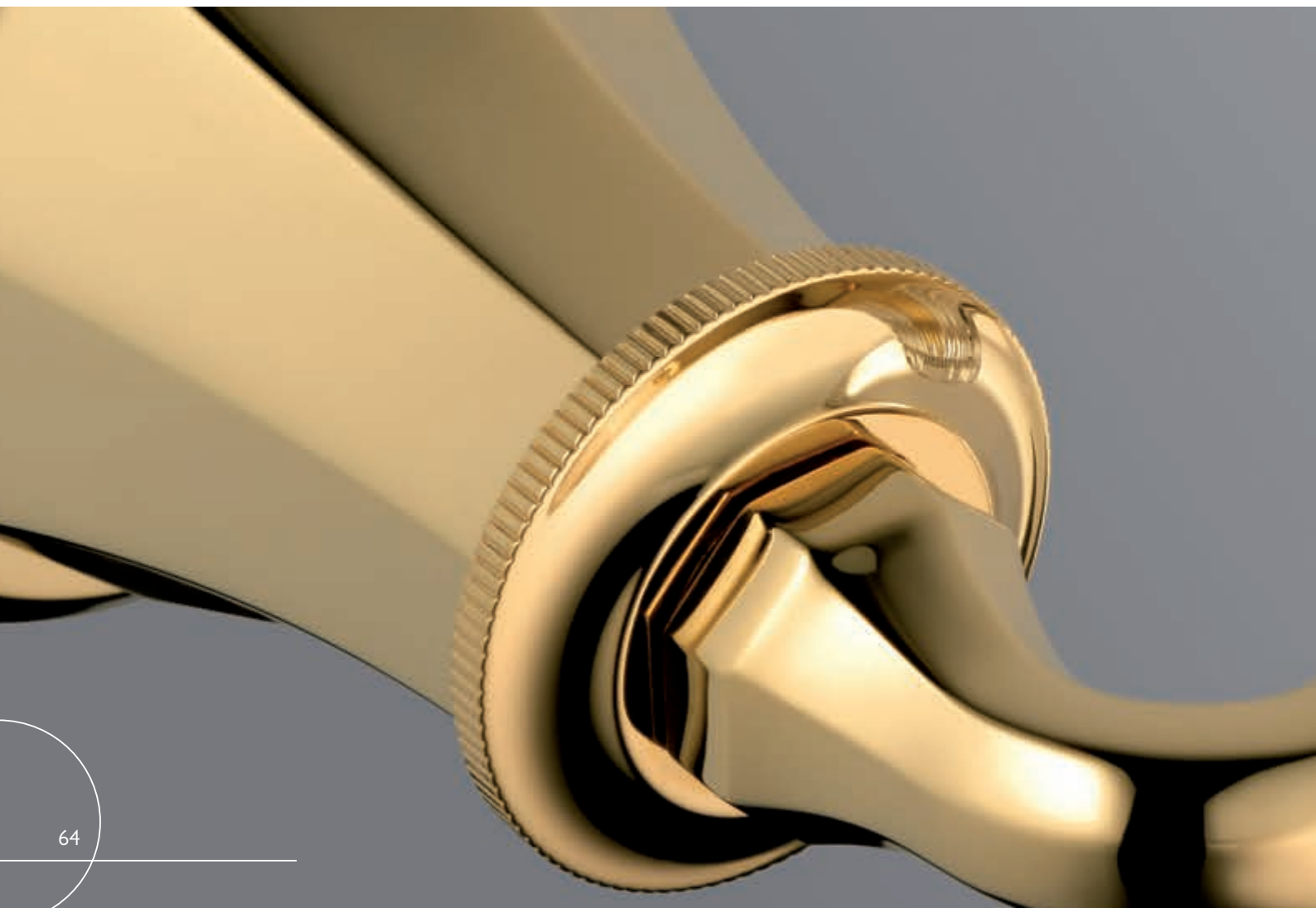

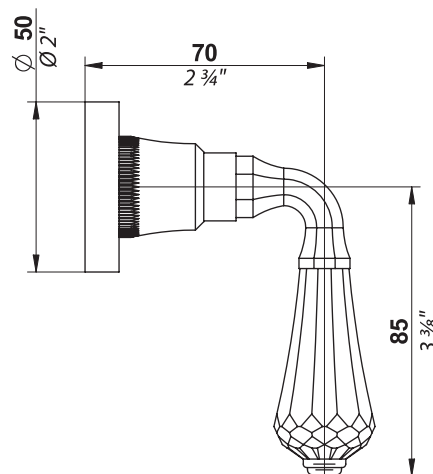

Art Déco Cristal

Poignée de porte - Carré de 7 & 8 mm

Door handle - 7 & 8mm spindle

Türklinke - Stift 7 & 8 mm

L'unité / Per piece / ProStück - Ref. A11.639/A56

La paire / Per pair / Das Paar - Ref. A11.638/A56

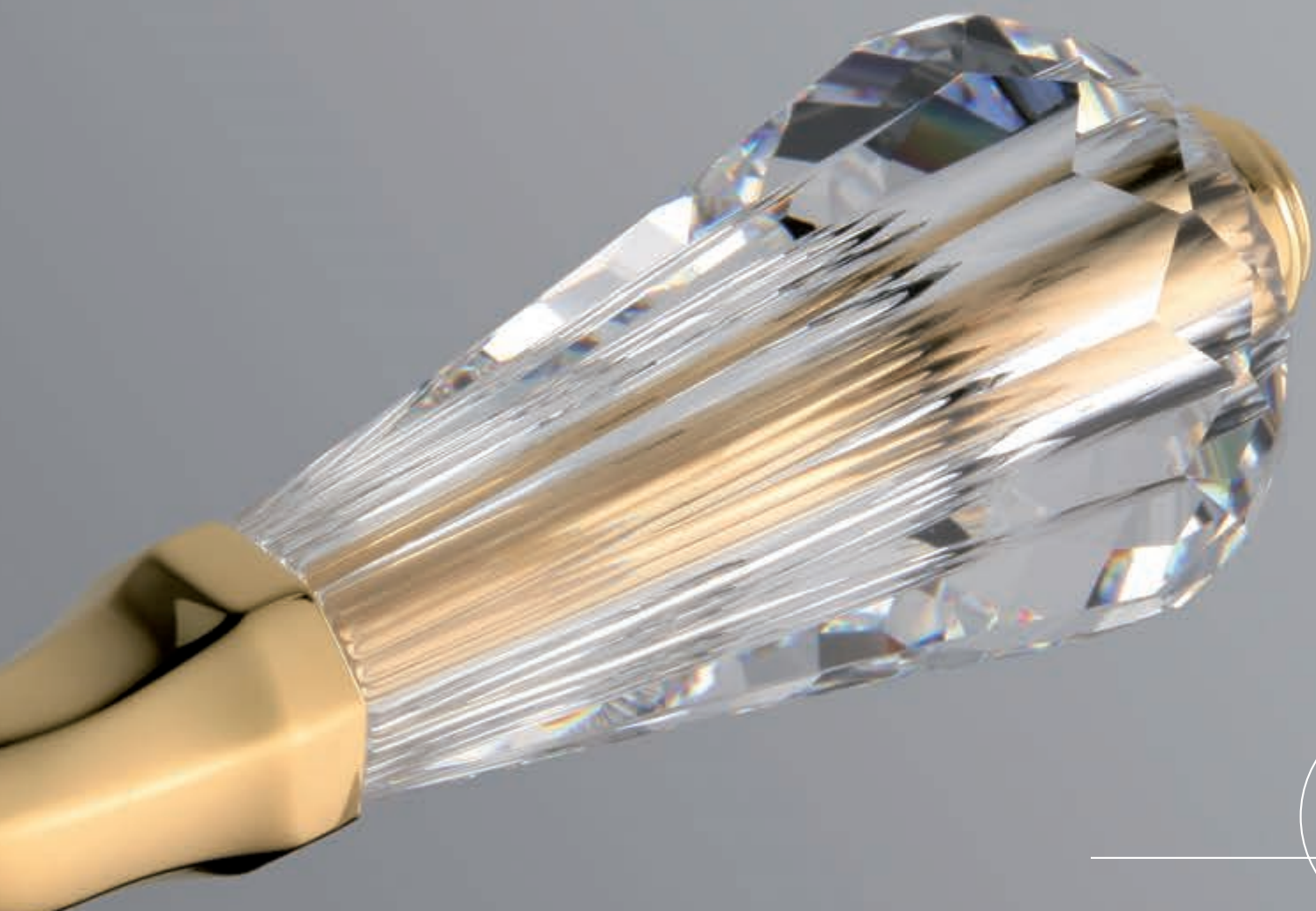



Quand le classique s'impose comme valeur de référence.

When classical shapes emerge as a reference value.

Wenn klassische Werte sich zur guten Referenz durchsetzen.





Tradition

Bouton moyen modèle
Medium size cabinet knob
Mittelgrosser Knopf
Ref. A11.26BP/A57

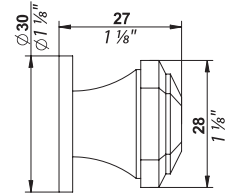

Tradition

Bouton grand modèle / Door knob / Grosser Knopf
L'unité / Per piece / ProStück - Ref. A11.639V/A57
La paire / Per pair / Das Paar - Ref. A11.638V/A57

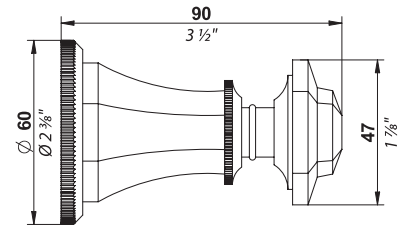

Tradition manette

Poignée fixe / Static handle / Statische Türklinke
L'unité / Per piece / ProStück - Ref. A11.639V/A58
La paire / Per pair / Das Paar - Ref. A11.638V/A58

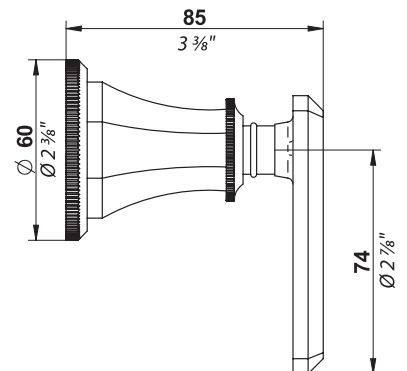

Tradition manette

Poignée de porte - Carré de 7 & 8 mm
Door handle - 7 & 8mm spindle
Türklinke - Stift 7 & 8 mm
L'unité / Per piece / ProStück - Ref. A11.639/A58
La paire / Per pair / Das Paar - Ref. A11.638/A58

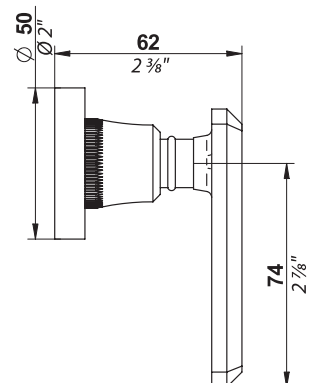



Art Déco

Bouton moyen modèle
Medium size cabinet knob
Mittelgrosser Knopf
Ref. A11.26BP/A54

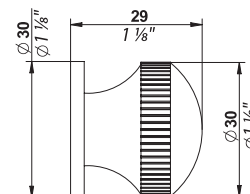

Art Déco

Bouton grand modèle / Door knob / Grosser Knopf
L'unité / Per piece / ProStück - Ref. A11.639V/A54
La paire / Per pair / Das Paar - Ref. A11.638V/A54

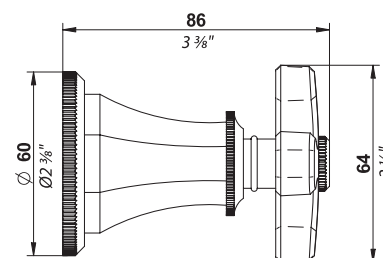

Art Déco manette

Poignée fixe / Static handle / Statische Türklinke
L'unité / Per piece / ProStück - Ref. A11.639V/A55
La paire / Per pair / Das Paar - Ref. A11.638V/A55

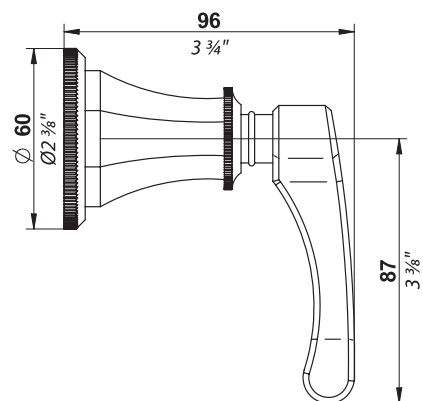

Art Déco manette

Poignée de porte - Carré de 7 & 8 mm
Door handle - 7 & 8mm spindle
Türklinke - Stift 7 & 8 mm
L'unité / Per piece / ProStück - Ref. A11.639/A55
La paire / Per pair / Das Paar - Ref. A11.638/A55

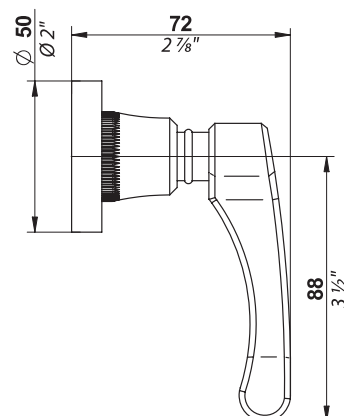



Diplomate torsadée

Bouton petit modèle
Small size cabinet knob
Kleiner Knopf
Ref. A I I.26BT/U4C

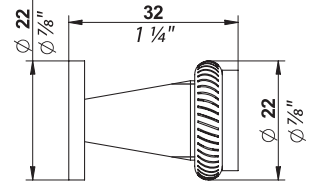

Diplomate torsadée

Bouton moyen modèle
Medium size cabinet knob
Mittelgrosser Knopf
Ref. A I I.26BP/U4C

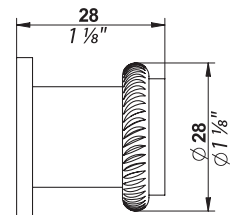

Diplomate torsadée

- 1 Bouton grand modèle / Door knob / Grosser Knopf
L'unité / Per piece / ProStück - Ref. A I I.639V/U4C
La paire / Per pair / Das Paar - Ref. A I I.638V/U4C
- 2 Poignée de porte - Carré de 7 & 8 mm
Door handle - 7 & 8mm spindle
Türknoopf - Stift 7 & 8 mm
L'unité / Per piece / ProStück - Ref. A I I.639/U4C
La paire / Per pair / Das Paar - Ref. A I I.638/U4C

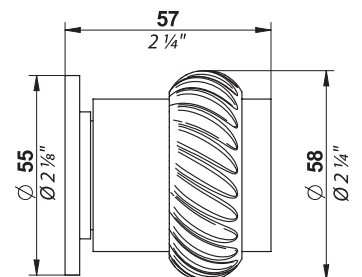

- 1 Bouton grand modèle
Door knob
Grosser Knopf

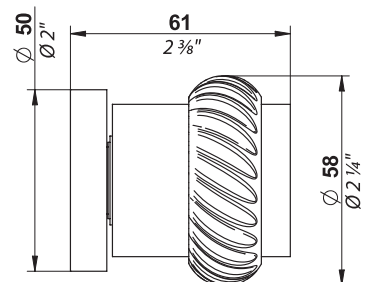

- 2 Poignée de porte
Door handle
Türknoopf



Broadway

Bouton moyen modèle
Medium size cabinet knob
Mittelgrosser Knopf
Ref. A11.26BP/A52

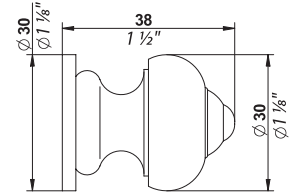

1900

Poignée de porte - Carré de 7 & 8 mm
Door handle - 7 & 8mm spindle
Türklinke - Stift 7 & 8 mm
L'unité / Per piece / ProStück - Ref. A11.639/G28
La paire / Per pair / Das Paar - Ref. A11.638/G28

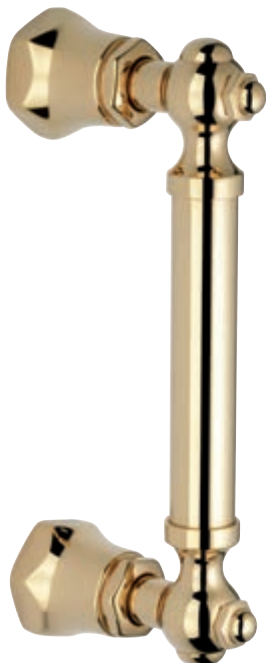
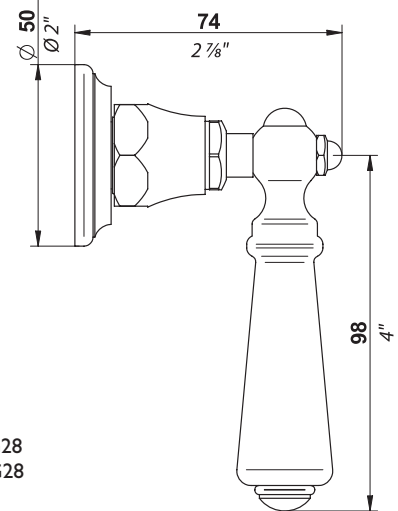

1900

Paire de poignées
Set of 2 door handles
Stangengriff als Paar
La paire / Per pair / Das Paar - Ref. A11.637V/G25

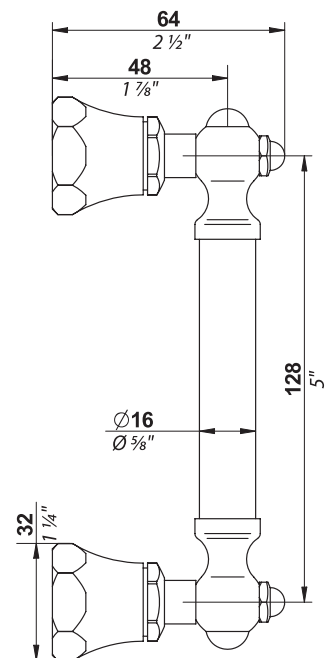



Quand la frivolité du baroque s'exprime
par la richesse des formes.

*When baroque's frivolity is expressed
by the richness of shapes.*

Wenn sich verspielte Frivolität durch
die barocken Linien ausdrückt.





Médisis

Bouton moyen modèle
Medium size cabinet knob
Mittelgrosser Knopf
Ref. A11.26BP/A18

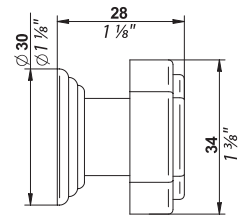

Médisis

- 1 Bouton grand modèle / Door knob / Grosser Knopf
L'unité / Per piece / ProStück - Ref. A11.639V/A18
La paire / Per pair / Das Paar - Ref. A11.638V/A18

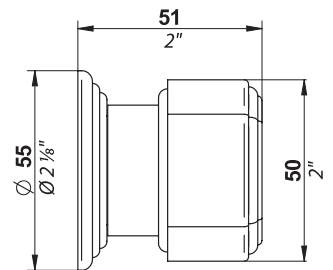

- 1 Bouton grand modèle
Door knob
Grosser Knopf



Médisis

- 2 Poignée de porte - Carré de 7 & 8 mm
Door handle - 7 & 8mm spindle
Türknoopf - Stift 7 & 8 mm
L'unité / Per piece / ProStück - Ref. A11.639/A18
La paire / Per pair / Das Paar - Ref. A11.638/A18

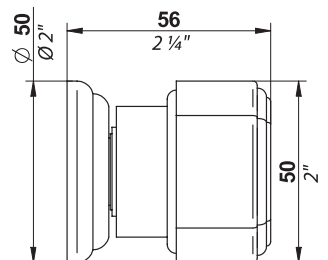

- 2 Poignée de porte
Door handle
Türknoopf



Venezia

Bouton moyen modèle
Medium size cabinet knob
Mittelgrosser Knopf
Ref. A11.26BP/A23

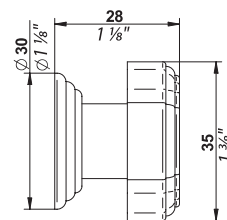

Venezia

- 1 Bouton grand modèle / Door knob / Grosser Knopf
L'unité / Per piece / ProStück - Ref. A11.639V/A23
La paire / Per pair / Das Paar - Ref. A11.638V/A23

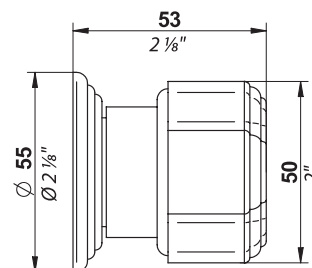

- 1 Bouton grand modèle
Door knob
Grosser Knopf



Venezia

- 2 Poignée de porte - Carré de 7 & 8 mm
Door handle - 7 & 8mm spindle
Türknohf - Stift 7 & 8 mm
L'unité / Per piece / ProStück - Ref. A11.639/A23
La paire / Per pair / Das Paar - Ref. A11.638/A23

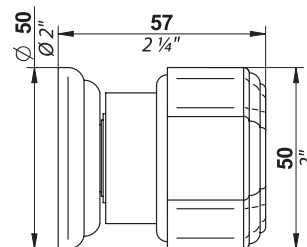

- 2 Poignée de porte
Door handle
Türknohf



Mandarine

Bouton petit modèle
Small size cabinet knob
Kleiner Knopf
Ref. A11.26BT/UIA

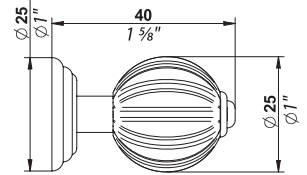

Mandarine

Bouton moyen modèle
Medium size cabinet knob
Mittelgrosser Knopf
Ref. A11.26BP/UIA

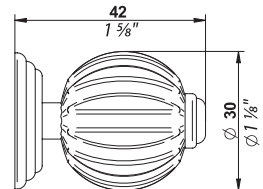

Mandarine

- ❶ Bouton grand modèle / Door knob / Grosser Knopf
L'unité / Per piece / ProStück - Ref. A11.639V/UIA
La paire / Per pair / Das Paar - Ref. A11.638V/UIA

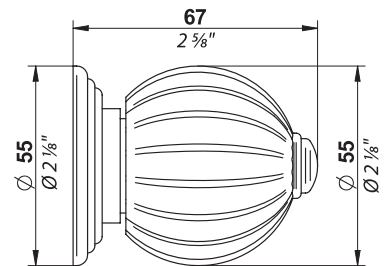

- ❶ Bouton grand modèle
Door knob
Grosser Knopf



Mandarine

- ❷ Poignée de porte - Carré de 7 & 8 mm
Door handle - 7 & 8mm spindle
Türknoopf - Stift 7 & 8 mm
L'unité / Per piece / ProStück - Ref. A11.639/UIA
La paire / Per pair / Das Paar - Ref. A11.638/UIA

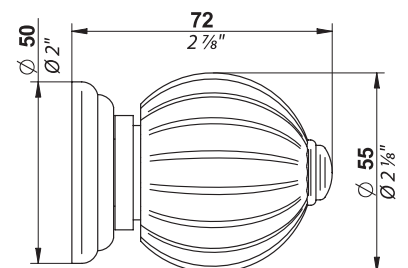

- ❷ Poignée de porte
Door handle
Türknoopf



Versailles

Bouton petit modèle
Small size cabinet knob
Kleiner Knopf
Ref. A11.26BT/G14

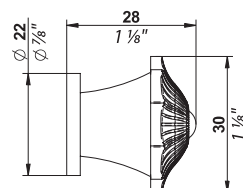

Versailles

- 1 Bouton grand modèle / Door knob / Grosser Knopf
L'unité / Per piece / ProStück - Ref. A11.639V/G14
La paire / Per pair / Das Paar - Ref. A11.638V/G14

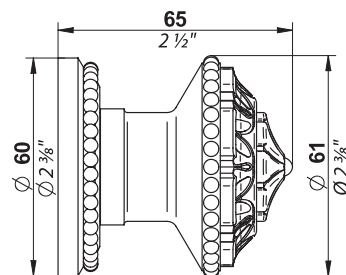

- 1 Bouton grand modèle
Door knob
Grosser Knopf



Versailles

- 2 Poignée de porte - Carré de 7 & 8 mm
Door handle - 7 & 8mm spindle
Türknoopf - Stift 7 & 8 mm
L'unité / Per piece / ProStück - Ref. A11.639/G14
La paire / Per pair / Das Paar - Ref. A11.638/G14

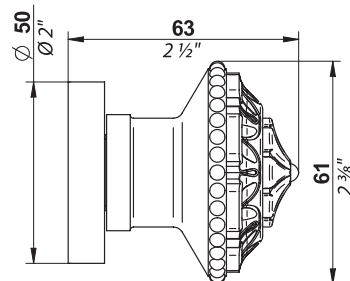

- 2 Poignée de porte
Door handle
Türknoopf



L'association harmonieuse de la richesse du métal
et de l'élégance des pierres.

*The harmonious combination of the metal richness
and the stones' elegance.*

Die Harmonische Verbindung des wertvollen
Metalls und die Eleganz der Steine.



Amboise

Bouton petit modèle
Small size cabinet knob
Kleiner Knopf



Cristal de roche / *Rock crystal* / Bergkristall
Ref. A11.26BT/A8F



Quartz rose / *Rose quartz* / Rosenquarz
Ref. A11.26BT/A8H

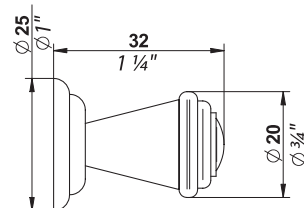

Amboise

Bouton petit modèle
Small size cabinet knob
Kleiner Knopf



Améthyste / *Amethyst* / Amethyst
Ref. A11.26BT/A8B



Jaspe rouge / *Red jasper* / Jaspis rot
Ref. A11.26BT/A1L



Lapis lazuli / *Lapis lazuli* // Lapis lazuli
Ref. A11.26BT/A1K



Malachite / *Malachite* / Malachit
Ref. A11.26BT/A1J



Œil de tigre / *Tiger eye* / Tigerauge
Ref. A11.26BT/A1Z



Onyx noir / *Black onyx* / Onyx schwarz
Ref. A11.26BT/A1M

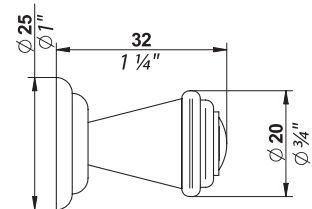

Autres pierres sur demande
More stones on request
Andere Steine auf Anfrage



Vogue

Cristal de roche / Rock crystal / Bergkristall

- ❶ Bouton grand modèle / Door knob / Grosser Knopf
L'unité / Per piece / ProStück - Ref. A I I .639V/A8F
La paire / Per pair / Das Paar - Ref. A I I .638V/A8F
- ❷ Poignée de porte - Carré de 7 & 8 mm
Door handle - 7 & 8mm spindle
Türknopf - Stift 7 & 8 mm
L'unité / Per piece / ProStück - Ref. A I I .639/A8F
La paire / Per pair / Das Paar - Ref. A I I .638/A8F



Vogue

Quartz rose / Rose quartz / Rosenquartz

- ❶ Bouton grand modèle / Door knob / Grosser Knopf
L'unité / Per piece / ProStück - Ref. A I I .639V/A8H
La paire / Per pair / Das Paar - Ref. A I I .638V/A8H
- ❷ Poignée de porte - Carré de 7 & 8 mm
Door handle - 7 & 8mm spindle
Türknopf - Stift 7 & 8 mm
L'unité / Per piece / ProStück - Ref. A I I .639/A8H
La paire / Per pair / Das Paar - Ref. A I I .638/A8H

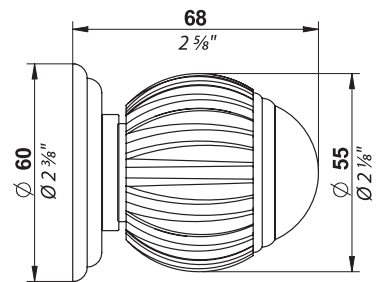

❶ Bouton grand modèle
Door knob
Grosser Knopf



Vogue

Améthyste / Amethyst / Amethyst

- ❶ Bouton grand modèle / Door knob / Grosser Knopf
L'unité / Per piece / ProStück - Ref. A I I .639V/A8B
La paire / Per pair / Das Paar - Ref. A I I .638V/A8B
- ❷ Poignée de porte - Carré de 7 & 8 mm
Door handle - 7 & 8mm spindle
Türknopf - Stift 7 & 8 mm
L'unité / Per piece / ProStück - Ref. A I I .639/A8B
La paire / Per pair / Das Paar - Ref. A I I .638/A8B

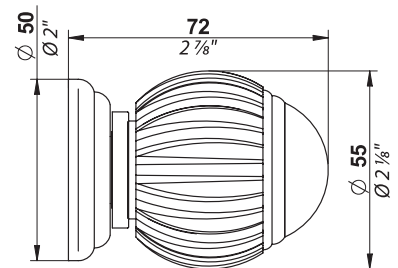

❷ Poignée de porte
Door handle
Türknopf



Vogue

Jaspe rouge / Red jasper / Jaspis rot

- ❶ Bouton grand modèle / Door knob / Grosser Knopf
L'unité / Per piece / ProStück - Ref. A I I .639V/A8N
La paire / Per pair / Das Paar - Ref. A I I .638V/A8N
- ❷ Poignée de porte - Carré de 7 & 8 mm
Door handle - 7 & 8mm spindle
Türknopf - Stift 7 & 8 mm
L'unité / Per piece / ProStück - Ref. A I I .639/A8N
La paire / Per pair / Das Paar - Ref. A I I .638/A8N



Vogue

Lapis lazuli / *Lapis lazuli* / Lapis lazuli

- ❶ Bouton grand modèle / *Door knob* / Grosser Knopf
L'unité / *Per piece* / ProStück - Ref. A11.639V/A8S
La paire / *Per pair* / Das Paar - Ref. A11.638V/A8S
- ❷ Poignée de porte - Carré de 7 & 8 mm
Door handle - 7 & 8mm spindle
Türkknopf - Stift 7 & 8 mm
L'unité / *Per piece* / ProStück - Ref. A11.639/A8S
La paire / *Per pair* / Das Paar - Ref. A11.638/A8S



Vogue

Malachite / *Malachite* / Malachit

- ❶ Bouton grand modèle / *Door knob* / Grosser Knopf
L'unité / *Per piece* / ProStück - Ref. A11.639V/A8M
La paire / *Per pair* / Das Paar - Ref. A11.638V/A8M
- ❷ Poignée de porte - Carré de 7 & 8 mm
Door handle - 7 & 8mm spindle
Türkknopf - Stift 7 & 8 mm
L'unité / *Per piece* / ProStück - Ref. A11.639/A8M
La paire / *Per pair* / Das Paar - Ref. A11.638/A8M

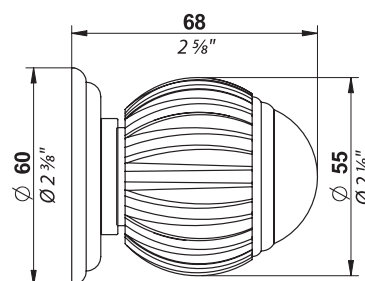

- ❶ Bouton grand modèle
Door knob
Grosser Knopf



Vogue

Œil de tigre / *Tiger eye* / Tigerauge

- ❶ Bouton grand modèle / *Door knob* / Grosser Knopf
L'unité / *Per piece* / ProStück - Ref. A11.639V/A8R
La paire / *Per pair* / Das Paar - Ref. A11.638V/A8R
- ❷ Poignée de porte - Carré de 7 & 8 mm
Door handle - 7 & 8mm spindle
Türkknopf - Stift 7 & 8 mm
L'unité / *Per piece* / ProStück - Ref. A11.639/A8R
La paire / *Per pair* / Das Paar - Ref. A11.638/A8R

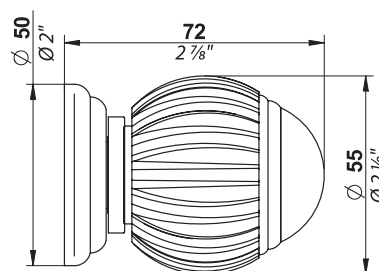

- ❷ Poignée de porte
Door handle
Türkknopf



Vogue

Onyx noir / *Black onyx* / Onyx schwarz

- ❶ Bouton grand modèle / *Door knob* / Grosser Knopf
L'unité / *Per piece* / ProStück - Ref. A11.639V/A8P
La paire / *Per pair* / Das Paar - Ref. A11.638V/A8P
- ❷ Poignée de porte - Carré de 7 & 8 mm
Door handle - 7 & 8mm spindle
Türkknopf - Stift 7 & 8 mm
L'unité / *Per piece* / ProStück - Ref. A11.639/A8P
La paire / *Per pair* / Das Paar - Ref. A11.638/A8P

Autres pierres sur demande
More stones on request
Andere Steine auf Anfrage



Cheverny

Jaspe rouge / Red jasper / Jaspis rot

- ❶ Bouton grand modèle / Door knob / Grosser Knopf
L'unité / Per piece / ProStück - Ref. A11.639V/AIU
La paire / Per pair / Das Paar - Ref. A11.638V/AIU
- ❷ Poignée de porte - Carré de 7 & 8 mm
Door handle - 7 & 8mm spindle
Türknohf - Stift 7 & 8 mm
L'unité / Per piece / ProStück - Ref. A11.639/AIU
La paire / Per pair / Das Paar - Ref. A11.638/AIU

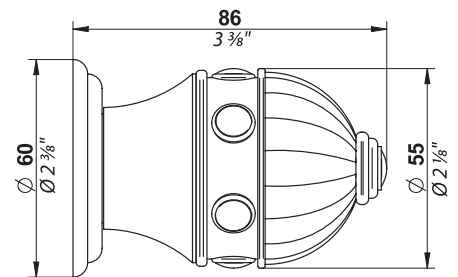

- ❶ Bouton grand modèle
Door knob
Grosser Knopf



Cheverny

Lapis lazuli / Lapis lazuli / Lapis lazuli

- ❶ Bouton grand modèle / Door knob / Grosser Knopf
L'unité / Per piece / ProStück - Ref. A11.639V/AIT
La paire / Per pair / Das Paar - Ref. A11.638V/AIT
- ❷ Poignée de porte - Carré de 7 & 8 mm
Door handle - 7 & 8mm spindle
Türknohf - Stift 7 & 8 mm
L'unité / Per piece / ProStück - Ref. A11.639/AIT
La paire / Per pair / Das Paar - Ref. A11.638/AIT

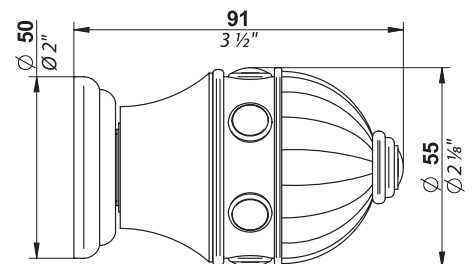

- ❷ Poignée de porte
Door handle
Türknohf



Cheverny

Malachite / Malachite / Malachit

- ❶ Bouton grand modèle / Door knob / Grosser Knopf
L'unité / Per piece / ProStück - Ref. A11.639V/AIS
La paire / Per pair / Das Paar - Ref. A11.638V/AIS
- ❷ Poignée de porte - Carré de 7 & 8 mm
Door handle - 7 & 8mm spindle
Türknohf - Stift 7 & 8 mm
L'unité / Per piece / ProStück - Ref. A11.639/AIS
La paire / Per pair / Das Paar - Ref. A11.638/AIS

Autres pierres sur demande
More stones on request
Andere Steine auf Anfrage



Sully

Jaspe rouge / Red jasper / Jaspis rot

- ❶ Bouton grand modèle / Door knob / Grosser Knopf
L'unité / Per piece / ProStück - Ref. A11.639V/AIX
La paire / Per pair / Das Paar - Ref. A11.638V/AIX
- ❷ Poignée de porte - Carré de 7 & 8 mm
Door handle - 7 & 8mm spindle
Türknohf - Stift 7 & 8 mm
L'unité / Per piece / ProStück - Ref. A11.639/AIX
La paire / Per pair / Das Paar - Ref. A11.638/AIX

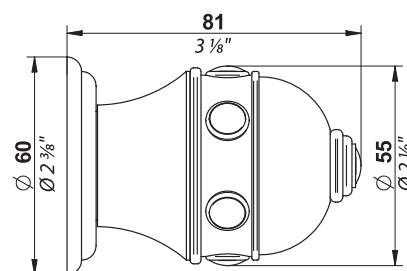

- ❶ Bouton grand modèle
Door knob
Grosser Knopf



Sully

Lapis lazuli / Lapis lazuli / Lapis lazuli

- ❶ Bouton grand modèle / Door knob / Grosser Knopf
L'unité / Per piece / ProStück - Ref. A11.639V/AIW
La paire / Per pair / Das Paar - Ref. A11.638V/AIW
- ❷ Poignée de porte - Carré de 7 & 8 mm
Door handle - 7 & 8mm spindle
Türknohf - Stift 7 & 8 mm
L'unité / Per piece / ProStück - Ref. A11.639/AIW
La paire / Per pair / Das Paar - Ref. A11.638/AIW

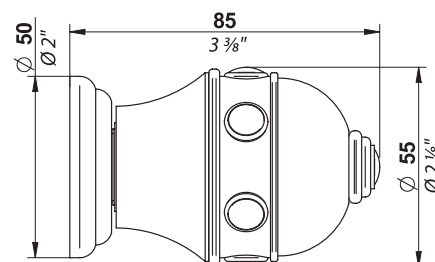

- ❷ Poignée de porte
Door handle
Türknohf



Sully

Malachite / Malachite / Malachit

- ❶ Bouton grand modèle / Door knob / Grosser Knopf
L'unité / Per piece / ProStück - Ref. A11.639V/AIV
La paire / Per pair / Das Paar - Ref. A11.638V/AIV
- ❷ Poignée de porte - Carré de 7 & 8 mm
Door handle - 7 & 8mm spindle
Türknohf - Stift 7 & 8 mm
L'unité / Per piece / ProStück - Ref. A11.639/AIV
La paire / Per pair / Das Paar - Ref. A11.638/AIV

Autres pierres sur demande
More stones on request
Andere Steine auf Anfrage



Trocadéro

Jaspe rouge / Red jasper / Jaspis rot

- ❶ Bouton grand modèle / Door knob / Grosser Knopf
L'unité / Per piece / ProStück - Ref. A11.639V/U7C
La paire / Per pair / Das Paar - Ref. A11.638V/U7C
- ❷ Poignée de porte - Carré de 7 & 8 mm
Door handle - 7 & 8mm spindle
Türknohf - Stift 7 & 8 mm
L'unité / Per piece / ProStück - Ref. A11.639/U7C
La paire / Per pair / Das Paar - Ref. A11.638/U7C



Trocadéro

Lapis lazuli / Lapis lazuli / Lapis lazuli

- ❶ Bouton grand modèle / Door knob / Grosser Knopf
L'unité / Per piece / ProStück - Ref. A11.639V/U7B
La paire / Per pair / Das Paar - Ref. A11.638V/U7B
- ❷ Poignée de porte - Carré de 7 & 8 mm
Door handle - 7 & 8mm spindle
Türknohf - Stift 7 & 8 mm
L'unité / Per piece / ProStück - Ref. A11.639/U7B
La paire / Per pair / Das Paar - Ref. A11.638/U7B



Trocadéro

Malachite / Malachite / Malachit

- ❶ Bouton grand modèle / Door knob / Grosser Knopf
L'unité / Per piece / ProStück - Ref. A11.639V/U7A
La paire / Per pair / Das Paar - Ref. A11.638V/U7A
- ❷ Poignée de porte - Carré de 7 & 8 mm
Door handle - 7 & 8mm spindle
Türknohf - Stift 7 & 8 mm
L'unité / Per piece / ProStück - Ref. A11.639/U7A
La paire / Per pair / Das Paar - Ref. A11.638/U7A



Trocadéro

Onyx noir / Black onyx / Onyx schwarz

- ❶ Bouton grand modèle / Door knob / Grosser Knopf
L'unité / Per piece / ProStück - Ref. A11.639V/U7D
La paire / Per pair / Das Paar - Ref. A11.638V/U7D
- ❷ Poignée de porte - Carré de 7 & 8 mm
Door handle - 7 & 8mm spindle
Türknohf - Stift 7 & 8 mm
L'unité / Per piece / ProStück - Ref. A11.639/U7D
La paire / Per pair / Das Paar - Ref. A11.638/U7D



Trocadéro

Œil de tigre / Tiger eye / Tigerauge

- ❶ Bouton grand modèle / Door knob / Grosser Knopf
L'unité / Per piece / ProStück - Ref. A11.639V/U7E
La paire / Per pair / Das Paar - Ref. A11.638V/U7E
- ❷ Poignée de porte - Carré de 7 & 8 mm
Door handle - 7 & 8mm spindle
Türknohf - Stift 7 & 8 mm
L'unité / Per piece / ProStück - Ref. A11.639/U7E
La paire / Per pair / Das Paar - Ref. A11.638/U7E

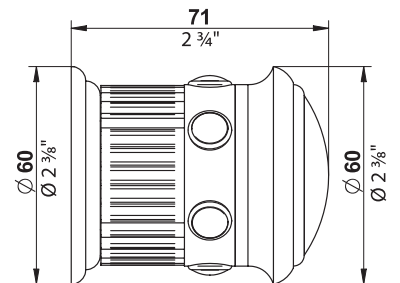

❶ Bouton grand modèle
Door knob
Grosser Knopf

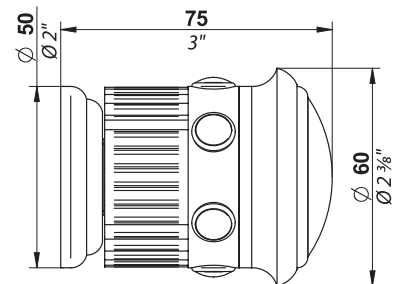

❷ Poignée de porte
Door handle
Türknohf

Autres pierres sur demande
More stones on request
Andere Steine auf Anfrage



Jaipur

Cristal satiné / *Satin crystal* / *Kristall satiniert*

- ❶ Bouton grand modèle / *Door knob* / *Grosser Knopf*
L'unité / *Per piece* / *ProStück* - Ref. A11.639V/A9B
La paire / *Per pair* / *Das Paar* - Ref. A11.638V/A9B
- ❷ Poignée de porte - Carré de 7 & 8 mm
Door handle - 7 & 8mm spindle
Türknopf - Stift 7 & 8 mm
L'unité / *Per piece* / *ProStück* - Ref. A11.639/A9B
La paire / *Per pair* / *Das Paar* - Ref. A11.638/A9B



Jaipur

Quartz rose / *Rose quartz* / *Rosenquartz*

- ❶ Bouton grand modèle / *Door knob* / *Grosser Knopf*
L'unité / *Per piece* / *ProStück* - Ref. A11.639V/A9D
La paire / *Per pair* / *Das Paar* - Ref. A11.638V/A9D
- ❷ Poignée de porte - Carré de 7 & 8 mm
Door handle - 7 & 8mm spindle
Türknopf - Stift 7 & 8 mm
L'unité / *Per piece* / *ProStück* - Ref. A11.639/A9D
La paire / *Per pair* / *Das Paar* - Ref. A11.638/A9D



Jaipur

Onyx noir / *Black onyx* / *Onyx schwarz*

- ❶ Bouton grand modèle / *Door knob* / *Grosser Knopf*
L'unité / *Per piece* / *ProStück* - Ref. A11.639V/A9C
La paire / *Per pair* / *Das Paar* - Ref. A11.638V/A9C
- ❷ Poignée de porte - Carré de 7 & 8 mm
Door handle - 7 & 8mm spindle
Türknopf - Stift 7 & 8 mm
L'unité / *Per piece* / *ProStück* - Ref. A11.639/A9C
La paire / *Per pair* / *Das Paar* - Ref. A11.638/A9C

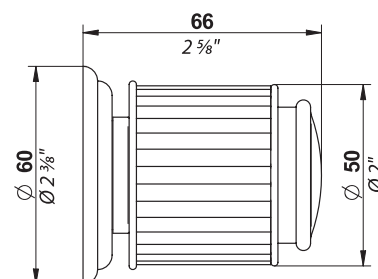

- ❶ Bouton grand modèle
Door knob
Grosser Knopf

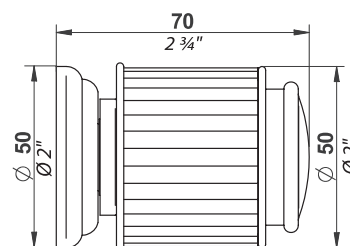

- ❷ Poignée de porte
Door handle
Türknopf

Autres pierres sur demande
More stones on request
Andere Steine auf Anfrage

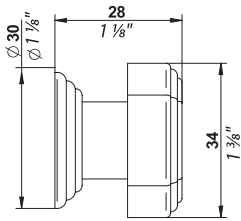

Médicis Pierre

Bouton moyen modèle
Medium size cabinet knob
Mittelgrosser Knopf



Jaspe rouge
Red jasper / Jaspis rot
Ref. A11.26BP/A3B



Lapis lazuli
Lapis lazuli / Lapis lazuli
Ref. A11.26BP/A3E



Malachite
Malachite / Malachit
Ref. A11.26BP/A3F



Œil de tigre
Tiger eye / Tigerauge
Ref. A11.26BP/A3G



Onyx noir
Black onyx / Onyx schwarz
Ref. A11.26BP/A3C



Médicis

Jaspe rouge / Red jasper / Jaspis rot

- 1 Bouton grand modèle / Door knob / Grosser Knopf
L'unité / Per piece / ProStück - Ref. A11.639V/A3B
La paire / Per pair / Das Paar - Ref. A11.638V/A3B

- 2 Poignée de porte - Carré de 7 & 8 mm
Door handle - 7 & 8mm spindle
Türknopf - Stift 7 & 8 mm
L'unité / Per piece / ProStück - Ref. A11.639/A3B
La paire / Per pair / Das Paar - Ref. A11.638/A3B



Médicis

Lapis lazuli / Lapis lazuli / Lapis lazuli

- 1 Bouton grand modèle / Door knob / Grosser Knopf
L'unité / Per piece / ProStück - Ref. A11.639V/A3E
La paire / Per pair / Das Paar - Ref. A11.638V/A3E

- 2 Poignée de porte - Carré de 7 & 8 mm
Door handle - 7 & 8mm spindle
Türknopf - Stift 7 & 8 mm
L'unité / Per piece / ProStück - Ref. A11.639/A3E
La paire / Per pair / Das Paar - Ref. A11.638/A3E



Médicis

Malachite / Malachite / Malachit

- 1 Bouton grand modèle / Door knob / Grosser Knopf
L'unité / Per piece / ProStück - Ref. A11.639V/A3F
La paire / Per pair / Das Paar - Ref. A11.638V/A3F
- 2 Poignée de porte - Carré de 7 & 8 mm
Door handle - 7 & 8mm spindle
Türknoopf - Stift 7 & 8 mm
L'unité / Per piece / ProStück - Ref. A11.639/A3F
La paire / Per pair / Das Paar - Ref. A11.638/A3F



Médicis

Œil de tigre / Tiger eye / Tigerauge

- 1 Bouton grand modèle / Door knob / Grosser Knopf
L'unité / Per piece / ProStück - Ref. A11.639V/A3G
La paire / Per pair / Das Paar - Ref. A11.638V/A3G
- 2 Poignée de porte - Carré de 7 & 8 mm
Door handle - 7 & 8mm spindle
Türknoopf - Stift 7 & 8 mm
L'unité / Per piece / ProStück - Ref. A11.639/A3G
La paire / Per pair / Das Paar - Ref. A11.638/A3G



Médicis

Onyx noir / Black onyx / Onyx schwarz

- 1 Bouton grand modèle / Door knob / Grosser Knopf
L'unité / Per piece / ProStück - Ref. A11.639V/A3C
La paire / Per pair / Das Paar - Ref. A11.638V/A3C
- 2 Poignée de porte - Carré de 7 & 8 mm
Door handle - 7 & 8mm spindle
Türknoopf - Stift 7 & 8 mm
L'unité / Per piece / ProStück - Ref. A11.639/A3C
La paire / Per pair / Das Paar - Ref. A11.638/A3C

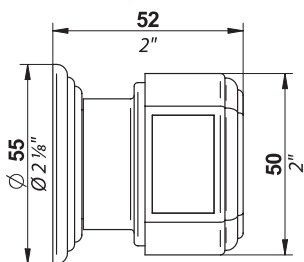

1 Bouton grand modèle
Door knob
Grosser Knopf

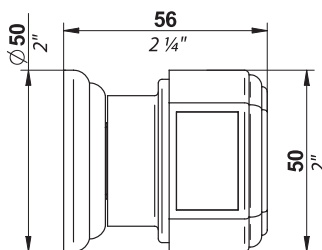

2 Poignée de porte
Door handle
Türknoopf

Autres pierres sur demande
More stones on request
Andere Steine auf Anfrage

PIERRE
VENEZIA PIERRE

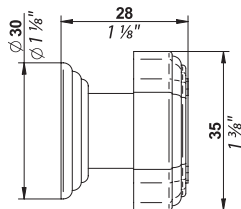

Venezia Pierre

Bouton moyen modèle
Medium size cabinet knob
Mittelgrosser Knopf



Jaspe rouge
Red jasper / Jaspis rot
Ref. A11.26BP/A3J



Lapis lazuli
Lapis lazuli / Lapis lazuli
Ref. A11.26BP/A3M



Malachite
Malachite / Malachit
Ref. A11.26BP/A3N



Œil de tigre
Tiger eye / Tigerauge
Ref. A11.26BP/A3P



Onyx noir
Black onyx / Onyx schwarz
Ref. A11.26BP/A3K



Venezia

Jaspe rouge / Red jasper / Jaspis rot

- 1 Bouton grand modèle / Door knob / Grosser Knopf
L'unité / Per piece / ProStück - Ref. A11.639V/A3J
La paire / Per pair / Das Paar - Ref. A11.638V/A3J
- 2 Poignée de porte - Carré de 7 & 8 mm
Door handle - 7 & 8mm spindle
Türkknopf - Stift 7 & 8 mm
L'unité / Per piece / ProStück - Ref. A11.639/A3J
La paire / Per pair / Das Paar - Ref. A11.638/A3J



Venezia

Lapis lazuli / Lapis lazuli / Lapis lazuli

- 1 Bouton grand modèle / Door knob / Grosser Knopf
L'unité / Per piece / ProStück - Ref. A11.639V/A3M
La paire / Per pair / Das Paar - Ref. A11.638V/A3M
- 2 Poignée de porte - Carré de 7 & 8 mm
Door handle - 7 & 8mm spindle
Türkknopf - Stift 7 & 8 mm
L'unité / Per piece / ProStück - Ref. A11.639/A3M
La paire / Per pair / Das Paar - Ref. A11.638/A3M



Venezia

Malachite / *Malachite* / Malachit

- 1 Bouton grand modèle / Door knob / Grosser Knopf
L'unité / Per piece / ProStück - Ref. A11.639V/A3N
La paire / Per pair / Das Paar - Ref. A11.638V/A3N
- 2 Poignée de porte - Carré de 7 & 8 mm
Door handle - 7 & 8mm spindle
Türknohf - Stift 7 & 8 mm
L'unité / Per piece / ProStück - Ref. A11.639/A3N
La paire / Per pair / Das Paar - Ref. A11.638/A3N



Venezia

Œil de tigre / *Tiger eye* / Tigerauge

- 1 Bouton grand modèle / Door knob / Grosser Knopf
L'unité / Per piece / ProStück - Ref. A11.639V/A3P
La paire / Per pair / Das Paar - Ref. A11.638V/A3P
- 2 Poignée de porte - Carré de 7 & 8 mm
Door handle - 7 & 8mm spindle
Türknohf - Stift 7 & 8 mm
L'unité / Per piece / ProStück - Ref. A11.639/A3P
La paire / Per pair / Das Paar - Ref. A11.638/A3P



Venezia

Onyx noir / *Black onyx* / Onyx schwarz

- 1 Bouton grand modèle / Door knob / Grosser Knopf
L'unité / Per piece / ProStück - Ref. A11.639V/A3K
La paire / Per pair / Das Paar - Ref. A11.638V/A3K
- 2 Poignée de porte - Carré de 7 & 8 mm
Door handle - 7 & 8mm spindle
Türknohf - Stift 7 & 8 mm
L'unité / Per piece / ProStück - Ref. A11.639/A3K
La paire / Per pair / Das Paar - Ref. A11.638/A3K

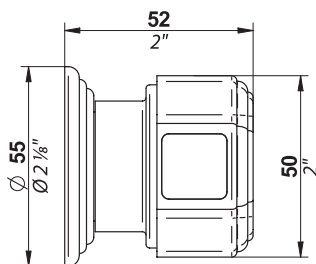

1 Bouton grand modèle
Door knob
Grosser Knopf

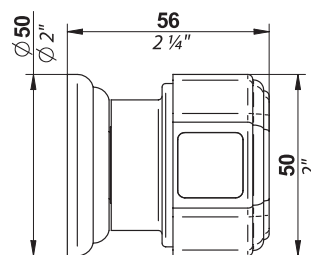

2 Poignée de porte
Door handle
Türknohf

Autres pierres sur demande
More stones on request
Andere Steine auf Anfrage





ACCESSOIRES POIGNÉES DE PORTE
HARDWARE



Ref. 2R1



Ref. 2R2



Ref. 2R3

Entrée de clé
Rosette for key-hole
Buntbart

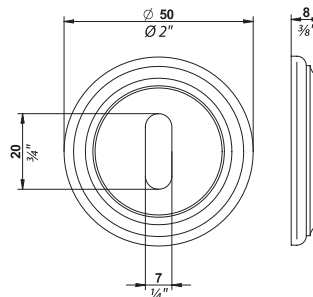
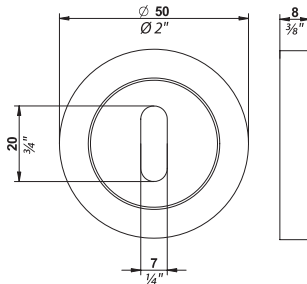
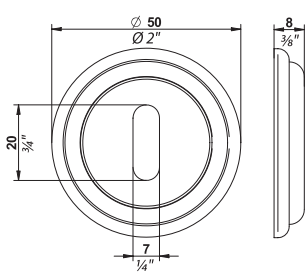

Ref. 8R1



Ref. 8R2



Ref. 8R3

Rosace pleine
Cover rosette
Blindrosette

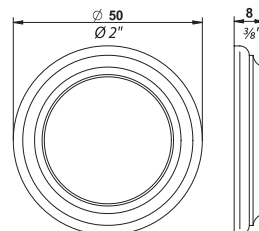
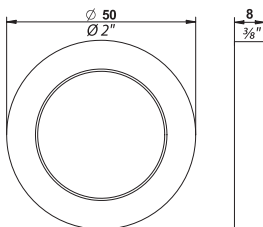
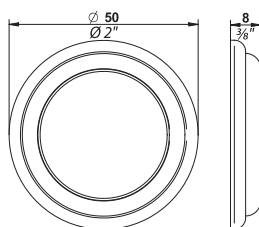



Ref. 3R1



Ref. 3R2



Ref. 3R3

Bouton de condamnation
Privacy lock
Verriegelung

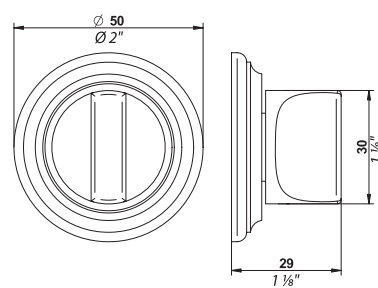
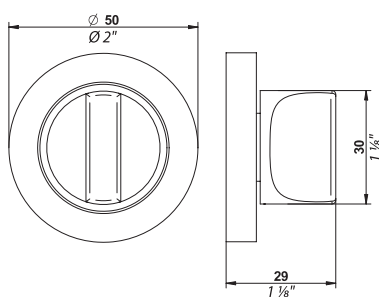
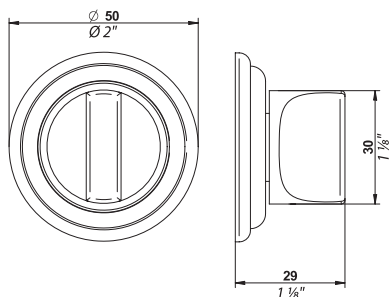

Ref. 4R1



Ref. 4R2



Ref. 4R3

Bouton de décondamnation
Emergency release
Entriegelung

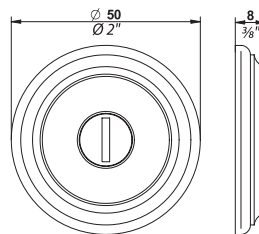
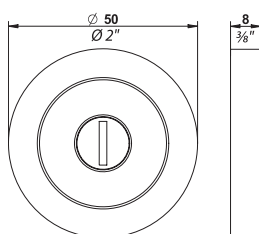
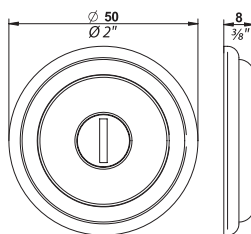

Ref. 9R1



Ref. 9R2



Ref. 9R3

Ensemble condamnation
& décondamnation
Privacy lock & emergency release
Verriegelung und Entriegelung

ACCESSOIRES POIGNÉES DE PORTE
HARDWARE



Ref. 5R1



Ref. 5R2



Ref. 5R3

Canon européen
Profil cylinder centers
Profil-Zylinder

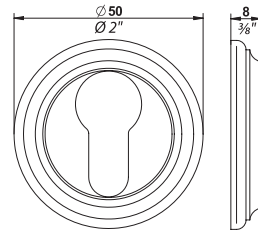
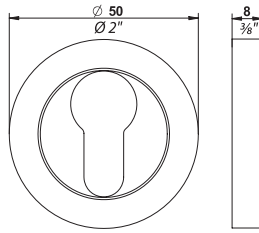
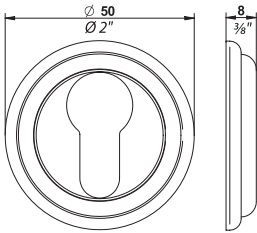

Ref. 6R1



Ref. 6R2



Ref. 6R3

Canon Ø22 mm
For Ø 22mm lock cylinder
22 mm Rund Zylinder

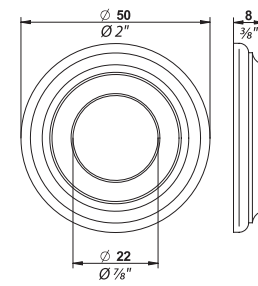
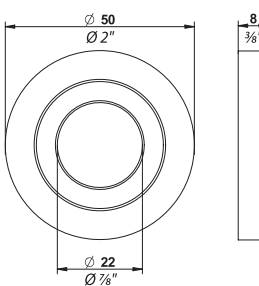
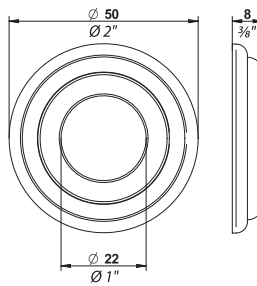

ACCESSOIRES POIGNÉES DE PORTE
HARDWARE



Ref. 7R1



Ref. 7R2



Ref. 7R3

Canon Ø 26 mm
For Ø 26mm lock cylinder
26 mm Rund Zylinder

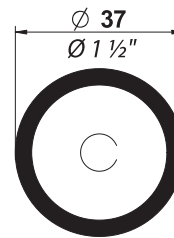
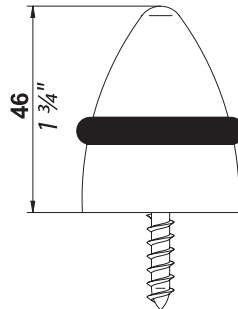
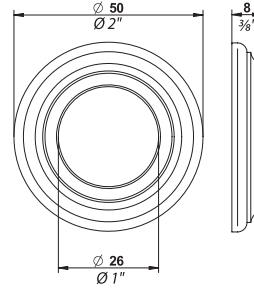
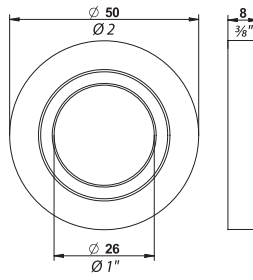
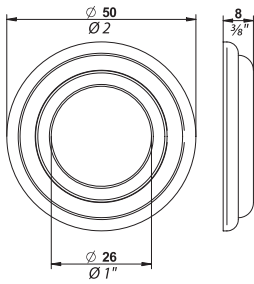

Butoir de sol
Floor mounted door stop
Türpuffer Boden

Ref. S1

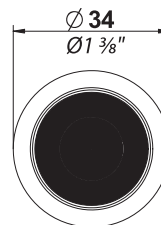
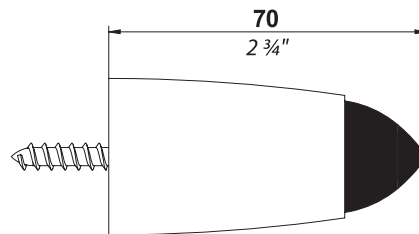

Butoir mural
Wall mounted door stop
Türpuffer Wand

Ref. Z1

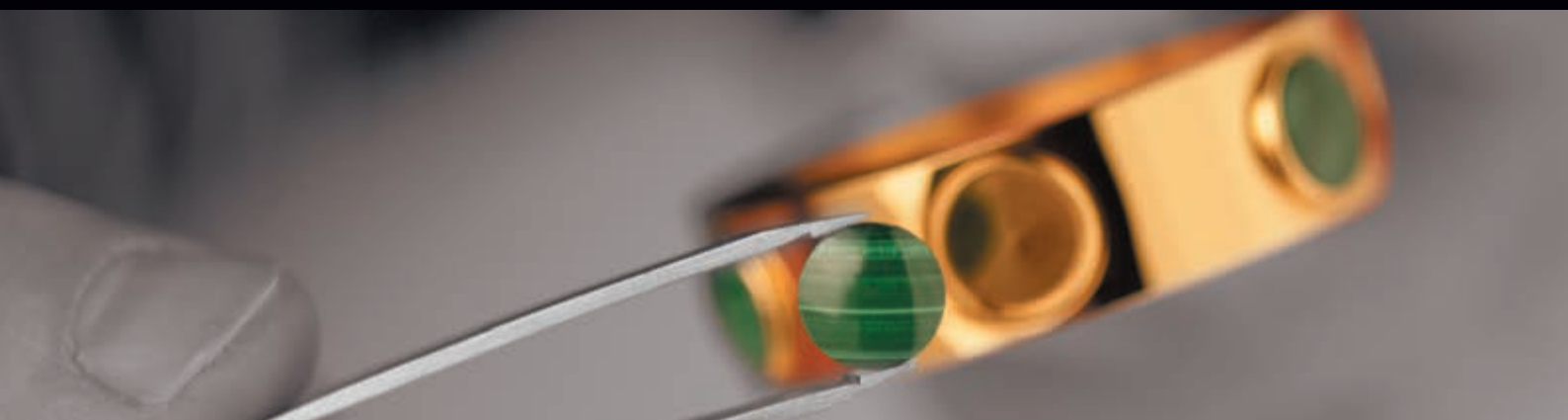

“THG démontre en permanence ses capacités d’adaptation et ses possibilités de développement de produits spécifiques”
N’hésitez pas à nous consulter..

*THG offers a wide range of models.
However, if you have specific requests
or needs we are able to answer them.
Don't hesitate to ask us...*

THG bietet eine sehr große Auswahl an verschiedenen Modellen. Wenn Sie jedoch besondere Wünsche oder Anforderungen haben, können wir auch denen gerecht werden. Wir stehen Ihnen jederzeit zur Verfügung..

Design et fabrication sur mesure

Customized design and manufacturing

Design und Herstellung nach Maß

Des solutions techniques...

Afin de répondre aux exigences les plus pointues, notre bureau d'étude est capable d'adapter et de concevoir des éléments techniques spécifiques.

Cartouches céramique, réducteurs de débit, systèmes anti-calcaire, mitigeurs progressifs, réducteurs de bruit... avec THG chaque problème technique est résolu par une solution spécifique adaptée.

Au gré de vos envies...

Choix des formes, choix des matières, notre bureau de design a le savoir-faire et la flexibilité nécessaires pour vous aider à concrétiser chacun de vos projets.

Personnalisez votre robinetterie, adaptez-là à votre image de marque, notre équipe est à l'écoute pour concrétiser vos rêves.

Technical solutions...

In order to meet the most demanding requirements, our engineering department is able to adapt and to conceive specific technical elements.

Ceramic cartridges, flow restrictors, anti-scale systems, progressive mixer taps, noise reducers... at THG each technical problem has its solution.

Depending on your project's needs...

Our design department will help you select the right style, function, and materials to meet the specific needs of your project.

We can personalize your fittings and adapt them to your brand; our team is listening to help you realize your dreams.

Technische Lösungen ...

Um auch höchste Ansprüche zu erfüllen, bietet Ihnen unsere Entwicklungsabteilung individuelle Entwürfe oder auch die Anpassung spezieller technischer Elemente.

Keramikkartuschen, Durchflussregler, Antikalk-Systeme, hoch moderne Mischbatterien, Geräuschdämpfer usw. – THG entwickelt für jedes technische Problem eine maßgeschneiderte Lösung.

Nach Ihren Wünschen und Anforderungen ...

Formen und Materialien frei wählen – unsere Designabteilung liefert das Know-how und die Flexibilität, um Sie bei der Umsetzung Ihrer Wünsche und Ideen zu unterstützen.

Entwerfen Sie individuelle Armaturen, die auf Ihre Marke abgestimmt sind – unser Team hilft Ihnen, Träume zu erfüllen.

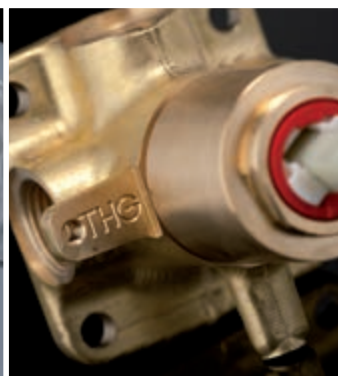



Un savoir-faire unique

A unique Know-How

Einzigartiges Know-How

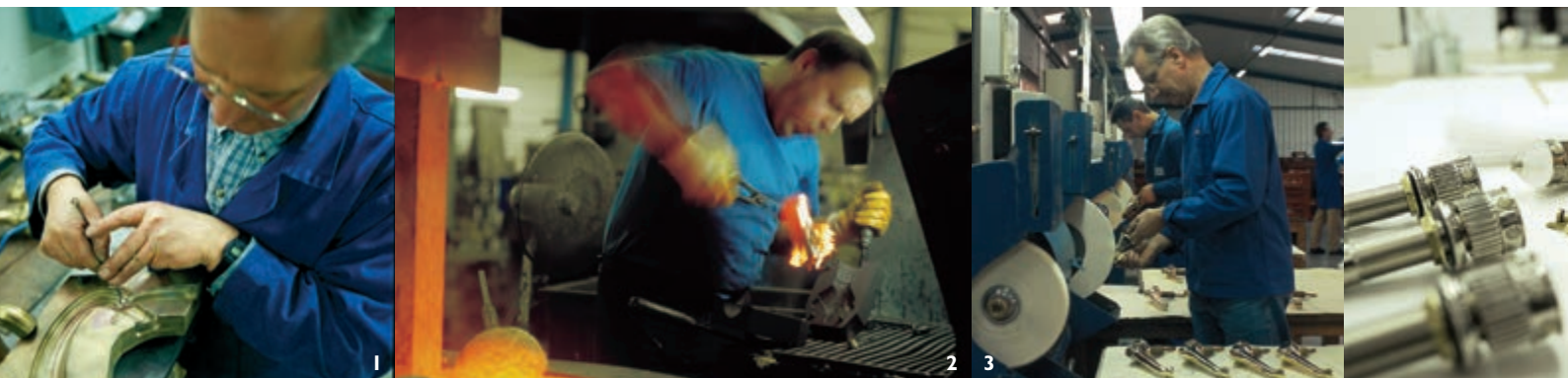

L'entreprise maîtrise tous les corps de métier, tous les savoir-faire qui interviennent dans la fabrication d'une robinetterie, d'un accessoire. La meilleure démonstration serait d'avoir un produit THG entre les mains. Finition, assemblage et générosité des matières parlent d'eux-mêmes. Tout concourt à vous faire comprendre que vous êtes en présence d'un produit d'exception, qui le restera au fil du temps.

La qualité des produits THG est le résultat de toute la politique de l'entreprise, dont voici les points essentiels :

- Plus de 10 métiers intégrés. Bureau d'études, outillage, fonderie, usinage, polissage, traitement de surface (respect de l'environnement : aucun rejet), assemblage...
- Compétence individuelle des hommes associée à la haute technologie (robots polisseurs, tours numériques...)
- Une grande largeur de gamme
 - Savoir-faire reconnu dans le monde entier.

The company is master of all trades, with all of the know-how involved in the manufacture of a valve or tap or accessory. The best demonstration would be to hold a THG product in one's hand. Finish, assembly and generosity of raw materials all speak for themselves. Everything conspires to make you believe that you are in the presence of an exceptional product, and one that will remain so through the years.

The quality of THG products is the result of every aspect of THG company policy, the essential points of which are as follows:

- *More than 10 trades incorporated into the product. Design, Research & Development, tooling, foundry, machining, polishing, plating (environment friendly: no refusal), assembly...*
- *The alliance of a craft know-how with modern equipment (polishing robots, N.C. drilling and threading machines...)*
- *Unequaled depth of range of elegant bathroom fittings.*
- *THG's know-how is recognised throughout the world.*

Das Unternehmen besitzt ein umfassendes Fachwissen in allen Fertigungsbereichen und das zur Herstellung von Armaturen und Zubehör erforderliche technische Know-how. Die Qualität ließe sich am einfachsten erklären, wenn Sie ein THG-Produkt in den eigenen Händen hielten. Oberflächenbearbeitung, Montage und Material sprechen für sich. Sie sehen und fühlen sofort, dass Sie ein außergewöhnlich-hochwertiges Produkt vor sich haben, das jahrelang einwandfrei funktionieren wird.

Diese Qualität aller THG Produkte ist das Ergebnis der gesamten Unternehmenspolitik von THG, die sich in folgenden Punkten zusammenfassen lässt:

- Mehr als 10 Berufsbereiche in der Herstellung. Planungsbüro, Werkzeugbau, Gießerei, Bearbeitung, Polierung, Oberflächenbehandlung (Schadstofflos und somit Umweltfreundlich), Montage...
- Fachkompetenz aller Mitarbeiter/innen im Umgang mit den hochtechnisierten Produktionsanlagen (wie z.B. Polierroboter, NC-Drehmaschinen...).
- Unübertroffen breite Produktpalette.
- Weltweit anerkanntes Know-how.

Étapes de fabrication

Manufacturing process

Die Fertigungsetappen



Design et bureau d'études

Conception des assemblages et outillages et réalisation des dessins techniques.

Outillage

Notre robinetterie et nos accessoires sont fabriqués à partir de lingots de laiton à 100%.

Fonderie

Le laiton en fusion est fondu à environ 900°C. La variété des équipements tant en noyautage qu'en moulage, rend possible la réalisation de pièces d'une grande variété.

Usinage

Equipée des centres numériques dernière génération, THG bénéficie du savoir-faire et des hommes sachant créer les produits répondant aux besoins de nos marchés.

Polissage

Chaque pièce de la robinetterie est soigneusement polie manuellement ou par robot.

Traitement de surface et vernissage

Tout en respectant les normes d'environnement les plus sévères, nous revêtons nos produits selon le desiderata de nos clients. La finition choisie est fixée par électrolyse sur la robinetterie et vernie pour les finitions cuivre et bronze.

Montage

Toutes les parties de la robinetterie sont assemblées par colle UV.

Expédition

Après contrôle final, les commandes clients sont emballées puis expédiées à travers le monde.

Un contrôle rigoureux est effectué à chaque étape de production.

Research, development and design Tooling

All our fittings and accessories are made of 100% brass ingot.

Foundry

The brass is cast around 900°C. The variety of the equipment, both coring and moulding, makes possible the creation of a large variety.

Machining

THG is equipped with the latest generation of numerical-control centres, but has nevertheless retained the know-how and the people capable of creating products which can satisfy the very different needs of our market.

Polishing

Each part of the faucet is carefully polished.

Plating workshop

While complying with the most constraining environmental standards, we finish our products according to the desires of our customers. The chosen finishing is settled by electrolysis on the faucet (or by varnishing for lacquers).

Assembly

All the parts of the faucets are UV-glued.

Shipping

After final inspection, the customer orders are packed and then shipped around the world by every conceivable means of transport.

A rigorous control is made at each step of the manufacturing.

Design und Planungsbüro Werkzeug

Unsere Armaturen und Zubehör werden aus 100% reinem Messing gefertigt.

Giesserei

Die Messingschmelze wird bei einer Temperatur von ca. 900°C gegossen. Mit den zahlreichen Ausrüstungsteilen der Giesserei lassen sich Produkte im Kern- und Einformverfahren fertigen und damit Teile eines vielseitigen Programms erstellen.

Bearbeitung

THG produziert mit der neuesten Generation der NC-Bearbeitungsanlagen. Die Mitarbeiter/innen besitzen ein entsprechendes fachliches Know-how, so dass Produkte geschaffen werden, die den Anforderungen des Markts voll entsprechen.

Polierung

Jedes einzelne Teil der Armaturen wird sorgfältig von Hand poliert oder mit einem Polierroboter bearbeitet.

Oberflächenbearbeitung

Die Oberflächenbearbeitung erfolgt unter Einsatz ausgesprochen umweltfreundlicher Verfahren nach den jeweiligen Kundenanforderungen. Die gewünschte Oberfläche- oder Lackschicht wird elektrolytisch auf dem Messingkörper aufgetragen.

Montage

Alle Bauteile einer Armatur werden im UV-Klebeverfahren zusammengebaut.

Versand

Nach der Endprüfung werden die Artikel kundenspezifisch verpackt und in alle Welt versandt.

Nach jedem wichtigen Arbeitsschritt des Produktionsablaufs erfolgt eine strenge Prüfung.

1. L'assemblage / Assembly / Montage
2. Contrôle qualité / Quality control / Qualitätskontrolle
3. Exemple de produit final / End product / Endprodukt

THG[®]

P A R I S

THG France

Siège social / Head office / Hauptsitz

35, rue Tournière
BP 80212 - Béthencourt sur Mer
80535 Friville cedex - France

Tél. +33 (0)3 22 60 20 80
Fax +33 (0)3 22 26 41 01
Email : contact@thg.fr
www.thg.fr

THG USA

6601 Lyons Road - Coconut Creek
FL 33073
USA

Tel: 954 425 8225
Fax: 954 425 8301
Email: info@thgusa.com
www.thgusa.com

THG Deutschland GmbH

Gutleustr. 96-96H
60329 Frankfurt/Main
Deutschland

Tel: +49 (0)69/25 78 14 33
Fax: +49 (0)69/25 78 14 35
Email: info@thg-deutschland.de
www.thg-deutschland.de

THG Asia Pacific

Room 1202, JinHang Tower
83 Wan Hang Du Road
Shanghai - PRC

中国上海静安区万航渡路83号金
航大厦1202室
Tel. +86 (21) 61352738
Fax +86 (21) 61352737
Email: contact@thg-asia.com
www.thg.fr

© Photos : Didier Grieu - Conception et réalisation : THG - Impression : Imp. Jean-Bernard - Edition : octobre 2011
Remerciements : Lalique - Bernardaud - Alberto Pinto - Jamie Drake - Pierre-Yves Rochon
François Gelly (Hôtel Keppler) - Philippe Chancel (Hôtel Les Crayères) - Stylmar (Belgique)

Textes et photos non contractuels et susceptibles d'être modifiés sans préavis
Text and pictures are not binding and can be modified without any previous notice / Texte und Fotos sind nicht Vertragsbestandteil, Änderungen vorbehalten.

THG[®]
P A R I S

*Boutons
& Poignées*